

FIBARO DOOR/WINDOW SENSOR FGK-10x

CONTENTS

v2.0

#1: Description and features	4	#7: Operating the device	10
#2: Basic activation	5	#8: Association	12
#3: Adding/removing the device	6	#9: Advanced parameters	13
#4: Temperature sensor	7	#10: Specifications	19
#5: Button or external sensor	8	#11: Regulations	20
#6: Physical installation	9		

Important safety information



Read this manual before attempting to install the device!

Failure to observe recommendations included in this manual may be dangerous or cause a violation of the law. The manufacturer, Fibar Group S.A. will not be held responsible for any loss or damage resulting from not following the instructions of operating manual.

General information about the FIBARO System

FIBARO is a wireless smart home automation system, based on the Z-Wave protocol. All of available devices can be controlled through a computer (PC or Mac), smartphone or tablet. Z-Wave devices are not only receivers, but can also repeat the signal, increasing the Z-Wave network's range. It gives advantage over traditional wireless systems that require direct link between transmitter and receiver, as a result the construction of the building could affect network's range negatively.

Every Z-Wave network has its unique identification number (home ID). Multiple independent networks can exist in the building without interfering. Transmission security of FIBARO System is comparable to wired systems.

Z-Wave technology is the leading solution in smart home automation. There is a wide range of Z-Wave devices that are mutually compatible, independently of manufacturer. It gives the system the ability to evolve and expand over time. For more information visit: www.fibaro.com.

#1: Description and features

FIBARO Door/Window Sensor is a wireless, battery powered reed sensor compatible with the Z-Wave standard. Changing the device's status will automatically send signal to the Z-Wave controller and associated devices.

Sensor can be used to trigger scenes and everywhere there is a need for information about opening or closing of doors, windows, garage doors, etc. Opening is detected by separating the sensor's body and the magnet.

In addition the FIBARO Door/Window Sensor supports one DS18B20 temperature sensor and has one potential free input.

i NOTE

This device may be used with all devices certified with Z-Wave Plus certificate and should be compatible with such devices produced by other manufacturers.

i NOTE

FIBARO Door/Window Sensor is a Security Enabled Z-Wave Plus product and a Security Enabled Z-Wave Controller must be used in order to fully utilize the product.

Main features of FIBARO Door/Window Sensor:

- Compatible with any Z-Wave or Z-Wave+ Controller,
- Supports protected mode (Z-Wave network security mode) with AES-128 encryption,
- Door/window opening detected through separation of Sensor's body and a magnet,
- Easily mounted on doors, windows, garage gates and roller blinds,
- Battery powered,
- Visual LED indicator signalling status of the device,
- Compatible with the DS18B20 temperature sensor,
- Potential-free input allowing to connect a button or binary sensor.



FIBARO Door/Window Sensor is a fully compatible Z-Wave PLUS device.

#2: Basic activation

1. Open the cover.

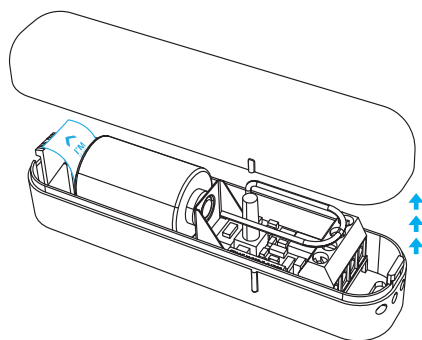

2. Remove the battery blocker.

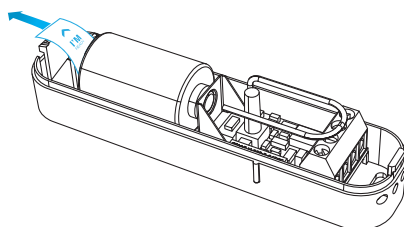

3. Close the cover.

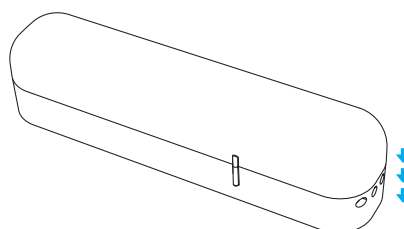

4. Add the device (see "Adding/removing the device" on page 6).
5. Install the device (see "Physical installation" on page 9).

i NOTE

The antenna should be placed above the battery. Never cut, shorten or bend the antenna. Its length is suited to the band at which the system operates.

i NOTE

Metal surfaces in close vicinity (e.g. metal switch boxes, metal door trims) may impair the reception capability.

#3: Adding/removing the device

i NOTE

Adding in security mode must be performed up to 2 meters from the controller.

i NOTE

In case the device is not added, please re-set the device and repeat the adding procedure.

i NOTE

Removing the device from the Z-Wave network restores all the default parameters of the device (except for parameter 20).

Adding (Inclusion) - Z-Wave device learning mode, allowing to add the device to existing Z-Wave network.

To add the device to the Z-Wave network:

1. Close the cover.
2. Place the Door/Window Sensor within the direct range of your Z-Wave controller.
3. Set the main controller into (security/non-security) add mode (see the controller's manual).
4. Quickly, three times press the TMP button.

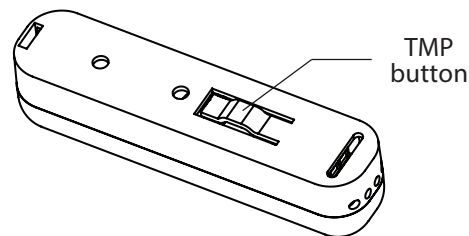

5. Wait for the adding process to end.
6. Successful adding will be confirmed by the Z-Wave controller's message.

Removing (Exclusion) - Z-Wave device learning mode, allowing to remove the device from existing Z-Wave network.

To remove the device from the Z-Wave network:

1. Close the cover.
2. Place the Door/Window Sensor within the direct range of your Z-Wave controller.
3. Set the main controller into remove mode (see the controller's manual).
4. Quickly, three times press the TMP button.

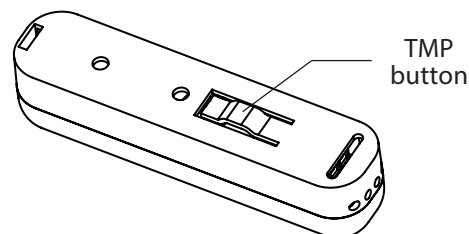

5. Wait for the removing process to end.
6. Successful removing will be confirmed by the Z-Wave controller's message.

#4: Temperature sensor

The DS18B20 temperature sensor may be installed anywhere where temperature readouts are necessary. If adequately protected, the DS18B20 sensor may be installed in humid conditions, under water, sealed in concrete or placed under the floor.

To activate the device with temperature measurement functionality:

1. Open the cover.
2. Connect the temperature sensor to terminals of the device according to the diagram:

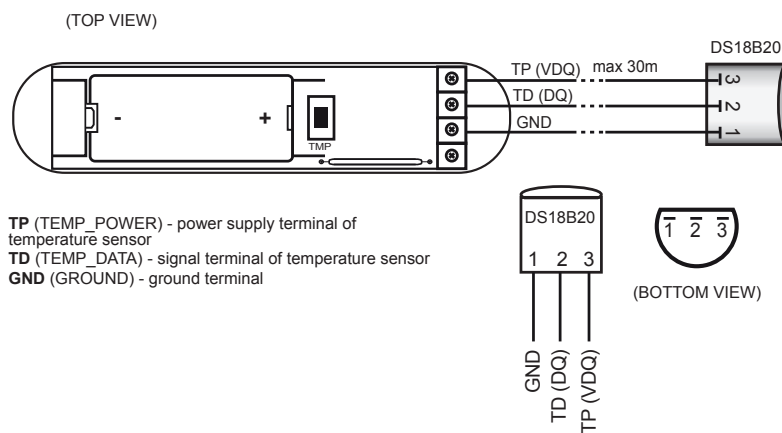

3. Add the device (see "Adding/removing the device" on page 6).
4. Install the device (see "Physical installation" on page 9).

CAUTION

Connected the device in accordance with the wiring diagram. Incorrect wiring may be dangerous or result in the device breakdown.

CAUTION

Connecting devices and sensors other than DS18B20 is not allowed.

NOTE

Connecting/disconnecting the temperature sensor to/from previously added Door/Window Sensor, requires removing and re-adding the device to the Z-Wave network.

#5: Button or external sensor

i NOTE

Potential-free input is a type of input contact which does not have a voltage on it after closing.

! CAUTION

Connected the device in accordance with the wiring diagram. Incorrect wiring may be dangerous or result in the device breakdown.

Door/Window Sensor is equipped with a potential-free input. It allows to change device state using the external button or sensor through GND signal.

If the Door/Window Sensor will be used only as a binary sensor, do not install the magnet.

To activate the device as a binary sensor:

1. Open the cover.
2. Connect the button or external sensor to terminals of the device according to diagram:

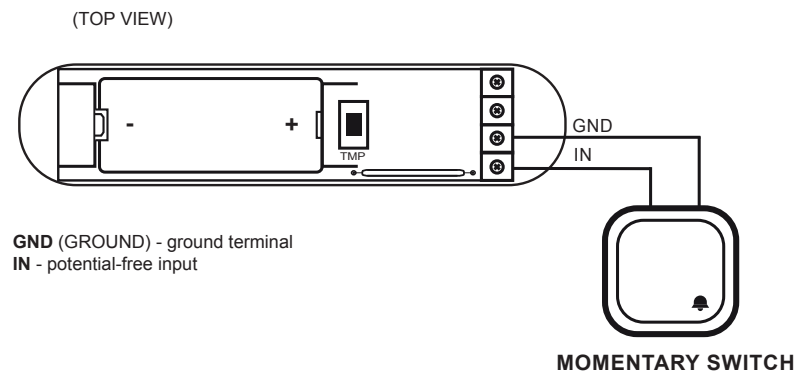

3. Add the device (see "Adding/removing the device" on page 6) if the device is not already added.
4. In case of connecting external sensor modify advanced parameter no. 20 to match type of the sensor, then remove and re-add the device to the network.
5. Install the device (see "Physical installation" on page 9).

#6: Physical installation

To install the Door/Window Sensor:

1. Stick the included self-adhesive pads to the bottom of the device and magnet.
2. Peel off the protective layer of the sticker.
3. Stick the device onto the door/window frame.
4. Stick the magnet onto the moving part of the door/window, no further than 5mm from the sensor.

Positioning of the Sensor and the magnet:

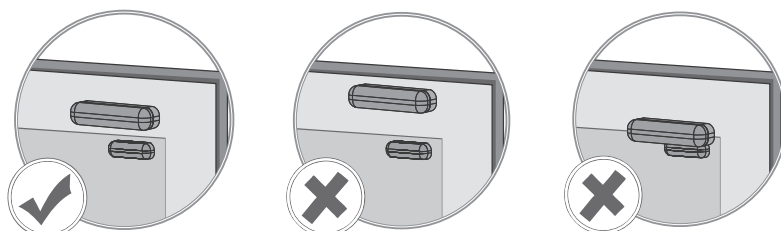

Correct positioning of the magnet in relation to the Sensor:

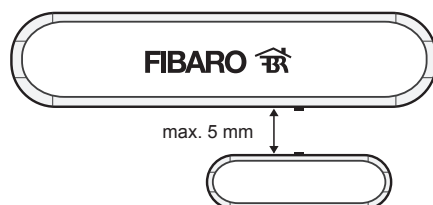

#7: Operating the device

Tamper (TMP) button:

The Door/Window Sensor is equipped with a tamper switch with two buttons.

First TMP button is located inside the device, pressed by the closed cover. Second TMP button is located at bottom of the device, pressed by the surface on which the device is mounted.

For the tamper switch to work one of the buttons must always be pressed!

When one of the buttons is released, the tamper alarm will be send to the controller and associated devices.

Additionally, tamper button allows to control the device directly.

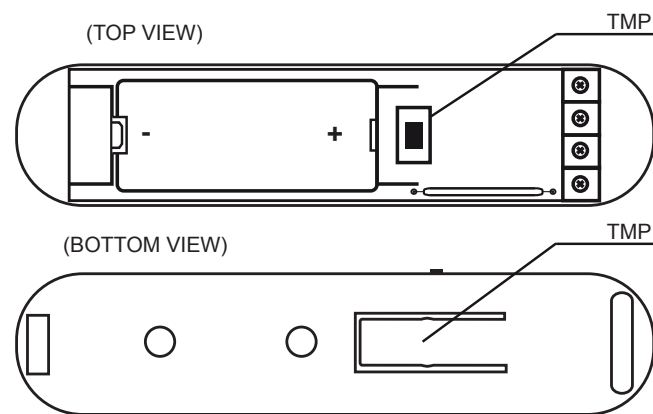

Controlling the Door/Window Sensor with FIBARO Home Center controller:

After adding the Sensor to the FIBARO System, it will be represented by one or two icons in Home Center interface.

Sensor without connected DS18B20 sensor or used with a button connected to IN input (without magnet), will be represented by a single icon.

In case of connecting DS18B20 temperature sensor, the additional temperature sensor icon will be displayed.

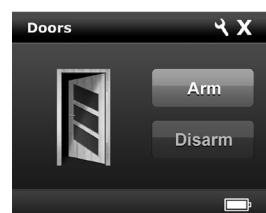

Waking up the Door/Window Sensor:

The Door/Window Sensor needs to be woken up to receive information about the new configuration from the controller, like parameters and associations.

To wake up the sensor manually, click one of the TMP buttons (while the other button is pressed).

Resetting the Door/Window Sensor:

Reset procedure deletes EEPROM's memory, including all information on the Z-Wave network and the main controller.

1. Open the cover.
2. Remove the battery.
3. Install the battery while holding both TMP buttons.
4. Release the TMP button within 5 seconds.
5. Visual indicator will blink 3 times to confirm launching of reset procedure.
6. Wait around 30s for the resetting process to end, do not remove the battery.
7. Visual LED indicator will blink 6 times to confirm the reset.

Replacing the battery:

Life of the battery included with the device is from 12 to 24 months (on default settings).

In FIBARO Home Center controller current battery level is displayed in the interface. If a battery icon turns red, it means the battery needs replacement.

NOTE

Opening the casing may result in triggering an alarm. To avoid it, remove the associations for the 5th group.

NOTE

Resetting the device is not the recommended way of removing the device from the Z-Wave network. Use reset procedure only if the primary controller is missing or inoperable. Certain device removal can be achieved by the procedure of removing described in "Adding/removing the device" on page 6.

CAUTION

There is a risk of explosion if the battery is replaced with an incorrect type. Batteries should be recycled where possible. Dispose of used batteries according to the environmental laws in your country.

#8: Association

NOTE

Association allows direct transfer of control commands between devices, is performed without participation of the main controller and requires associated device to be in direct range.

Association (linking devices) - direct control of other devices within the Z-Wave system network e.g. Dimmer, Relay Switch, Roller Shutter or scene (may be controlled only through a Z-Wave controller).

The Door/Window provides the association of five groups:

1st Association Group – “Lifeline” reports the device status and allows for assigning single device only (main controller by default).

2nd Association Group – “Control” is assigned to the device status - reed sensor and IN input (sends Basic Set command frames).

3rd Association Group – “Alarm” is assigned to the device status - reed sensor and IN input (sends alarm command frames). Its value may be modified via advanced parameters.

4th Association Group – “Sensor ZW3” is assigned to the device status - reed sensor and IN input (sends Basic Set command frames). This group provides backward compatibility with controllers not supporting Z-Wave+.

5th Association Group – “Tamper ZW3” is assigned to the TMP switch (sends alarm command frames). This group provides backward compatibility with controllers not supporting Z-Wave+.

The Door/Window Sensor in 2nd to 5th group allows to control 5 regular and 5 multichannel devices per an association group, with the exception of “LifeLine” that is reserved solely for the controller and hence only 1 node can be assigned.

It is not recommended to associate more than 10 devices in general, as the response time to control commands depends on the number of associated devices. In extreme cases, system response may be delayed.

To add an association (using the Home Center controller):

1. Go to device options by clicking the icon: 
2. Select the „Advanced” tab.
3. Specify to which group and what devices are to be associated.
4. Wait for the configuration process to end. Sending relevant information to devices added to associated groups may take even a few minutes.
5. Wake up the device manually to speed up the configuration process.

#9: Advanced parameters

The Door/Window Sensor allows to customize its operation to user's needs. Settings are available in the FIBARO interface as simple options that may be chosen by selecting the appropriate box.

In order to configure the Door/Window Sensor (using the Home Center controller):

1. Go to the device options by clicking the icon: 
2. Select the „Advanced“ tab.

Wake up interval

Available settings: **0** or **3600-64800** (in seconds, 1h - 18h)

Default setting: **21 600** (every 6 hours)

The Door/Window Sensor will wake up after each defined time interval and always try to connect with the main controller. After a successful communication attempt, the sensor will update configuration parameters, associations and settings and will go into standby mode. After failed communication attempt (e.g. lack of Z-Wave range) the device will go into standby mode and retry to establish connection with the main controller after the next time interval.

Setting wake up interval to 0 disables sending Wake Up Notification frame automatically. Wake up may be still performed manually by a single TMP button click.

Longer time interval means less frequent communication and thus a longer battery life.

1. Operation mode

Parameter defines device operation mode.

Available settings:	0 - Door/Window Sensor or external alarm sensor 1 - external button		
Default setting:	0	Parameter size:	1 [byte]

2. Door/Window or alarm status

Parameter defines state of the sensor when the magnet is close. If the alarm sensor is connected, it determines the output type. Parameter inactive in external button mode (parameter 1 set to 1).

Available settings:	0 - door/window closed 1 - door/window opened		
Default setting:	0	Parameter size:	1 [byte]

CAUTION

Do not install the magnet if the device is not used as a Door/Window Sensor, as it might lead to the malfunction of the device.

i NOTE

Values of parameter 3 may be combined, e.g. 1+2=3 means opening/closing and wake up will be indicated by the visual indicator.

3. Visual LED indications

This parameter defines events indicated by the visual LED indicator. Disabling events might extend battery life.

Available settings:	0 - no indications 1 - indication of opening/closing status change (input IN) 2 - indication of wake up (1 x click or periodical) 4 - indication of device tampering		
Default setting:	6	Parameter size:	1 [byte]

4. Range test after double click

Allows to enable activation of Z-Wave range test with double click of a TMP button.

Available settings:	0 - disabled 1 - enabled		
Default setting:	0	Parameter size:	1 [byte]

10. 2nd association group triggers

Parameter defines events which result in sending on/off commands to devices added to the 2nd association group. These commands are sent alternately to switch the devices on and off. Commands represent the values of BASIC SET command frames. Parameter is inactive in external button mode (parameter 1 set to 1).

Available settings:	0 - switch after opening and closing 1 - switch after opening 2 - switch after closing		
Default setting:	0	Parameter size:	1 [byte]

11. Commands sent to 2nd association group

Command frames sent to devices added to the 2nd association group.

Available settings:	0 - ON 1 - OFF 2 - ON & OFF		
Default setting:	2	Parameter size:	1 [byte]

12. Value of ON command frame sent to 2nd association group

The value of 0 turns OFF the device, 255 turns it ON. In case of associating the Dimmer or Roller Shutter module, values 1-99 allow to set an associated device to a specified level.

Available settings:	0-99 or 255		
Default setting:	255	Parameter size:	2 [bytes]

13. Value of OFF command frame sent to 2nd association group

The value of 0 turns OFF the device, 255 turns it ON. In case of associating the Dimmer or Roller Shutter module, values 1-99 allow to set an associated device to a specified level.

Available settings:	0-99 or 255		
Default setting:	0	Parameter size:	2 [bytes]

14. Time delay of ON command frame

Time period after which ON command frame will be sent.

Available settings:	0-32400 - time in seconds		
Default setting:	0	Parameter size:	2 [bytes]

15. Time delay of OFF command frame

Time period after which OFF command frame will be sent.

Available settings:	0-32400 - time in seconds		
Default setting:	0	Parameter size:	2 [bytes]

20. Type of sent alarm frames

Type of control frames transmitted to the main controller and 3rd association group "Alarm". If an external sensor is connected to IN input, it is possible to choose its functionality. Otherwise it is recommended to set this parameter to default value.

Available settings:	0 - Door/Window Sensor (General Purpose Alarm) 1 - smoke sensor (Smoke Alarm) 2 - CO detector (CO Alarm) 3 - CO2 detector (CO2 Alarm) 4 - high temperature sensor (Heat Alarm) 5 - flood sensor (Water Alarm)		
Default setting:	0	Parameter size:	1 [byte]

30. Delay of tamper alarm cancellation

Time period after which a tamper alarm will be cancelled.

Available settings:	0-32400 - time in seconds		
Default setting:	5	Parameter size:	2 [bytes]

31. Reporting tamper alarm cancellation

Reporting cancellation of tamper alarm to the controller and 5th association group.

Available settings:	0 - do not send tamper cancellation report 1 - send tamper cancellation report		
Default setting:	1	Parameter size:	1 [byte]

CAUTION

In order to activate new settings of parameter 20, it is required to remove and re-add the device to the main Z-Wave controller. This parameter is not reset during removal process.

i NOTE

Parameter 51 is active only if parameter 50 is not set to 0.

i NOTE

Temperature measurement is performed before sending any report (regardless of parameter no. 50). Excessive reporting can affect battery lifetime. Reporting on the basis of temperature change (parameter no. 51) is recommended.

50. Interval of temperature measurements

This parameter defines how often the temperature will be measured. The shorter the time, the more frequently the temperature will be measured, but the battery life will shorten.

Available settings:	0 - temperature measurements disabled 5-32400 - time in seconds		
Default setting:	300 (5min)	Parameter size:	2 [bytes]

51. Temperature reports threshold

This parameter defines the change of temperature in comparison with last reported, resulting in temperature report being sent to the main controller.

Available settings:	0 - temperature reports based on threshold disabled 1-300 - temperature threshold (0.1-30°C, 0.1°C step)		
Default setting:	10 (1°C)	Parameter size:	2 [bytes]

52. Interval of temperature reports

This parameter determines how often the temperature reports will be sent to the main controller.

Available settings:	0 - periodic temperature reports disabled 5-32400 - time in seconds		
Default setting:	0	Parameter size:	2 [bytes]

53. Temperature offset

The value to be added to the actual temperature, measured by the sensor (temperature compensation).

Available settings:	-1000-1000 (-100-100°C, 0.1°C step)		
Default setting:	0 (0°C)	Parameter size:	4 [bytes]

54. Temperature alarm reports

Temperature alarms reported to the Z-Wave controller. Thresholds are set in parameters 55 and 56.

Available settings:	0 - temperature alarms disabled 1 - high temperature alarm 2 - low temperature alarm 3 - high and low temperature alarms enabled		
Default setting:	0	Parameter size:	1 [byte]

55. High temperature alarm threshold

If temperature is higher than set value, overheat notification will be sent and high temperature scene will be triggered (if activated).

Available settings:	0-1000 (0-100°C, 0.1°C step)		
Default setting:	540 (54°)	Parameter size:	2 [bytes]

56. Low temperature alarm threshold

If temperature is lower than the set value, underheat notification will be sent and low temperature scene will be triggered (if activated).

Available settings:	-300-700 (-30-70°C, 0.1°C step)		
Default setting:	40 (4°)	Parameter size:	2 [bytes]

70. Scene activation functionality

The device can trigger scenes using scene IDs assigned to different events.

To deactivate all scenes set the value to 0. To activate all scenes set the value to 3903.

Available settings:	1 - [ID 10] opening door/window (single click) 2 - [ID 11] closing door/window (single click) 4 - [ID 12] holding 8 - [ID 13] releasing 16 - [ID 14] double click 32 - [ID 15] triple click 256 - [ID 50] high temperature - door/window opened 512 - [ID 50] high temperature - door/window closed 1024 - [ID 51] low temperature - door/window opened 2048 - [ID 51] low temperature - door/window closed		
Default setting:	0 (none)	Parameter size:	2 [bytes]

71. Alarm broadcast

Settings for broadcasting ON/OFF commands, sensor alarm and tamper alarm. Value other than 0 means alarms are sent in Broadcast Mode, to all devices only within the range of the device. They are not repeated by the mesh network.

Available settings:	0 - broadcasts inactive 1 - ON/OFF commands broadcast active 2 - sensor alarm broadcast active 4 - tamper alarm broadcast active		
Default setting:	0 (inactive)	Parameter size:	1 [byte]

CAUTION

Every activated scene may shorten the battery life.

NOTE

Values of parameter 70 may be combined, e.g. 1+2=3 means scenes for opening and closing are sent.

NOTE

Scenes with IDs 12 to 15 are active only if parameter 1 is set to 1. In this case scenes with IDs 1 and 2 are sent after a single click.

NOTE

Values of parameter 71 may be combined, e.g. 1+2=3 means ON/OFF commands and sensor alarm are sent in Broadcast Mode.

i NOTE

Operating in Z-Wave network security mode automatically disables sending alarms in broadcast mode.

i NOTE

Values of parameter 72 may be combined, e.g. 1+2=3 means 2nd and 3rd group are sent as secure.

72. Associations in Z-Wave network Security Mode

This parameter defines how commands are sent in specified association groups: as secure or non-secure. Parameter is active only in Z-Wave network security mode. It does not apply to 1st group "Lifeline".

Available settings:	0 - none of the groups sent as secure 1 - 2nd group "Control" sent as secure 2 - 3rd group "Alarm" sent as secure 4 - 4th group "Sensor ZW3" sent as secure 8 - 5th group "Tamper ZW3" sent as secure		
Default setting:	15 (all)	Parameter size:	1 [byte]

#10: Specifications

Power supply:	3.6V DC battery
Battery type:	ER14250 ½ AA
Inputs:	single, potential-free (IN)
EU directives compliance:	EMC 2014/30/EU RAD 2014/53/EU RoHS 2011/65/EU LVD 2014/35/EU
Radio protocol:	Z-Wave (500 series chip)
Radio frequency:	868.4 or 869.8 MHz EU; 908.4 or 916.0 MHz US; 921.4 or 919.8 MHz ANZ; 869.0 MHz RU;
Range:	up to 50m outdoors up to 40m indoors (depending on terrain and building structure)
Operating temperature:	0-40°C
Supported temperature sensor:	single, DS18B20
Dimensions (L x W x H):	76 x 17 x 19 mm

i NOTE

Radio frequency of individual device must be same as your Z-Wave controller. Check information on the box or consult your dealer if you are not sure.

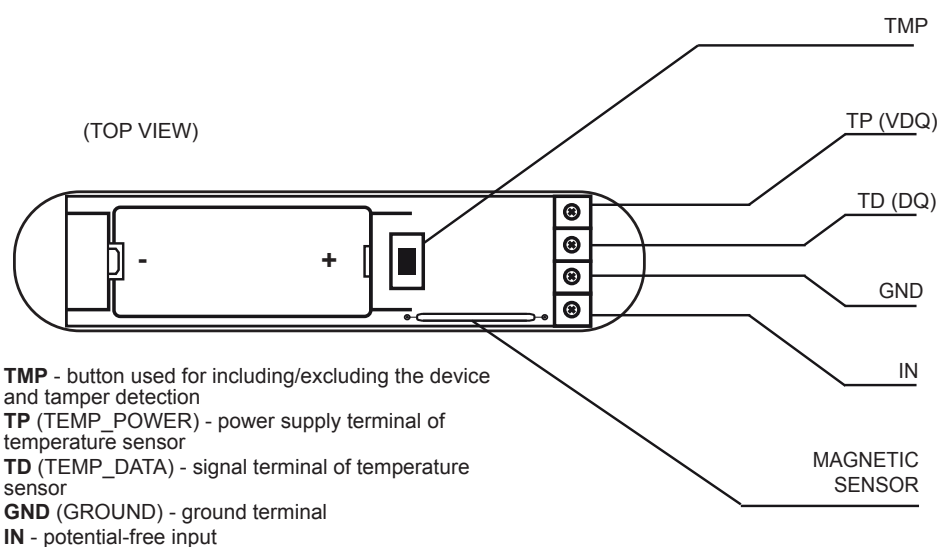

#11: Regulations

This device complies with Part 15 of the FCC Rules

Operation is subject to the following two conditions:

1. This device may not cause harmful interference
2. This device must accept any interference received, including interference that may cause undesired operation. This equipment has been tested and found to comply with the limits for a Class B digital device, pursuant to part 15 of the FCC Rules. These limits are designed to provide reasonable protection against harmful interference in a residential installation. This equipment generates, uses and can radiate radio frequency energy and, if not installed and used in accordance with the instructions, may cause harmful interference to radio communications. However, there is no guarantee that interference will not occur in a particular installation. If this equipment does cause harmful interference to radio or television reception, which can be determined by turning the equipment off and on, the user is encouraged to try to correct the interference by one or more of the following measures:

- Reorient or relocate the receiving antenna.
- Increase the separation between the equipment and receiver.
- Connect the equipment into an outlet on a circuit different from that to which the receiver is connected.
- Consult the dealer or an experienced radio/TV technician for help.

Industry Canada (IC) Compliance Notice

This device complies with Industry Canada license-exempt RSSs. Operation is subject to the following two conditions: (1) this device may not cause interference, and (2) this device must accept any interference, including interference that may cause undesired operation of the device.

Cet appareil est conforme aux normes d'exemption de licence RSS d'Industry Canada. Son fonctionnement est soumis aux deux conditions suivantes : (1) cet appareil ne doit pas causer d'interférence et (2) cet appareil doit accepter toute interférence, notamment les interférences qui peuvent affecter son fonctionnement.

Legal Notices

All information, including, but not limited to, information regarding the features, functionality, and/or other product specification are subject to change without notice. Fibaro reserves all rights to revise or update its products, software, or documentation without any obligation to notify any individual or entity.

FIBARO and Fibar Group logo are trademarks of Fibar Group S.A. All other brands and product names referred to herein are trademarks of their respective holders.

DGT Warning Statement

Article 12

Without permission, any company, firm or user shall not alter the frequency, increase the power, or change the characteristics and functions of the original design of the certified lower power frequency electric machinery.

Article 14

The application of low power frequency electric machineries shall not affect the navigation safety nor interfere a legal communication, if an interference is found, the service will be suspended until improvement is made and the interference no longer exists.

第十二條

經型式認證合格之低功率射頻電機，非經許可，公司、商號或使用者均不得擅自變更頻率、加大功率或變更原設計之特性及功能。

第十四條

低功率射頻電機之使用不得影響飛航安全及干擾合法通信；經發現有干擾現象時，應立即停用，並改善至無干擾時方得繼續使用。

前項合法通信，指依電信法規定作業之無線電通信。

低功率射頻電機須忍受合法通信或工業、科學及醫療用電波輻射性電機設備之干擾。

Declaration of conformity

Hereby, Fibar Group S.A. declares that FIBARO Door/Window Sensor is in compliance with the essential requirements and other relevant provisions of Directive 2014/53/EU.

