

# AC136

# Panic Button

The AC136 Panic Button is a Z-Wave Plus™ enabled device and is fully compatible with any Z-Wave™ enabled network. The device can be set up in a Z-Wave network to communicate directly with other end devices such as lighting controllers, or to report directly a Z-Wave controller (usually a gateway).

The Panic Button is a portable wireless switch designed to control the Panic/Disarm status of other associated devices thru the Z-Wave™ controller. After receiving the signals emitted by the Panic Button, the Z-Wave™ controller can then give commands or operate according to its own settings. Its great compatibility with Z-Wave™ products makes it suitable for smart home cloud based platforms.

## Product Overview

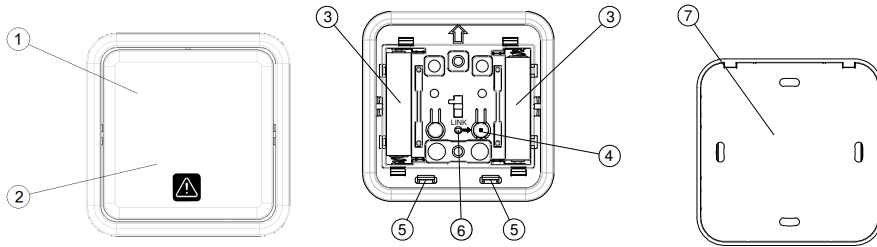

Front View			
①	Panic ON/OFF Knob	②	Panic ON/OFF Knob
Inside View			
③	Battery Compartments	④	Link Button
⑤	Rear Cover Latch	⑥	LED Indicator
Rear View			
⑦	Rear Cover		

## Adding to Z-Wave™ Network

### Auto Inclusion

The detector supports Auto Inclusion feature where it will automatically enter Inclusion mode when first powered up after a factory reset.

1. Gently lever the bottom edge of the front cover to detach it from the main body.
2. Put a Z-Wave Controller into inclusion mode.
3. Insert 2 AAA-size 1.5V alkaline batteries to battery compartment with the correct polarity. The LED on the device should turn ON.

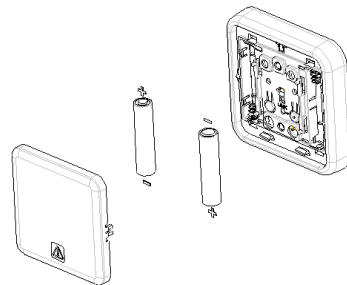

4. The Inclusion process should be completed when the LED turns off.

Note: If Auto Inclusion fails, refer to the Troubleshooting section regarding Manual Inclusion.

## Testing

1. For the Panic Button to control other devices on the Z-Wave™ controller by 2 seconds long pressing for Panic and 10 seconds long pressing for disarm, a Scenes needs to be created. Scenes are user defined elements in controller that determines what actions to take when an event occurs. The Panic Button creates the event to this Scene which then controls other activation devices such as plugs or dimmers, or perhaps set the alarm to Arm or Disarm mode.
2. After binding with the Z-Wave™ controller, the Panic Button will send data about its battery power to the Gateway after about 2 minutes. Subsequently it will send the data once the button is pressed..

## Installation

The Panic Button can be installed on the wall either by using the supplied double-sided tapes or the screws:

1. Using the double-sided tape: first peel one side of the tape and place the sticky side onto the back of the Panic Button. Then peel the other side of the tape and attach the unit onto a proper location on the wall.

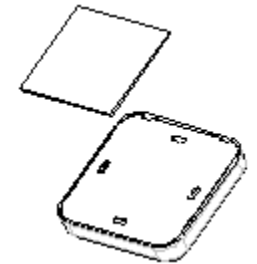

2. Using the screws:

- i. Detach the rear cover by removing the front cover and then pressing the rear cover latch (see item ⑤ in Product Overview).
- ii. Use the rear cover as a template to mark on the wall the positions of two screws. The marks should be in horizontal positions and the distance between the two marks is 60mm.
- iii. Drill the holes using an appropriate size drill bit. Insert the supplied plastic wall plugs first for a cement wall. For a wooden wall the wall plugs would not be needed.

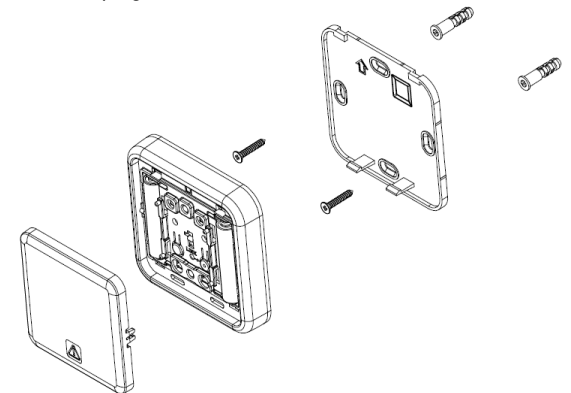

- iv. Position the rear cover on the wall and turn the two screws into the wall (or wall plugs). DO NOT fasten too tightly as the rear cover might be damaged. Then replace the main body and the front cover.

**Note:** Ensure the unit is installed within transmission range of the gateway using the test above.

## Maintenance

- Do not put the unit in humid or dusty places or facing direct sunlight.
- Do not place the unit near combustible substances or any source of heat, e.g. fires, radiators, boilers etc.
- The suitable ambient temperature for the unit is -10°C - +40°C.

Low Battery: The Panic Button will inform the Gateway when its battery runs low. Also, if the unit has completed binding with a Gateway and the front cover is detached, you can see the LED flashes once when you press the up/down key to indicate low battery condition.

## Programming

### Z-Wave Group

The unit supports either one of two Z-Wave Association Groups:

**Group 1:** Association with 1 Controller node.

**Group 2:** Association with 4 nodes (i.e. end devices such as smart plugs and other lighting controllers). This allows the On/Off module to receive commands directly from these end devices without the participation of the controller.

Group 1 commands:

- When the unit is powered for the first time, the unit will send a Notification Report to the node of Group 1.
- When device status being changed, the unit will send Notification command to the node of Grouping 1.
- Upon device status being changed, the unit will check its battery status simultaneously. When the battery level of the unit drops to an unacceptable level, the unit will emit Notification report to the nodes of Grouping 1.
- Device Reset: When performing Factory Reset the unit will send Device Reset Locally Notification to the node of Group1.

Group 2 commands:

- When device is pressed by Up key, the unit will send BASIC SET command which contains a value that is adjustable, to the nodes of Grouping 2.
- When device is pressed by Down key, the BASIC\_SET command will also be sent to the nodes of Grouping 2.

Role Type	Node Type	Installer Icon	User Icon
Slave Sleeping report	Z-Wave Plus node	Notification Sensor	Notification Sensor

### Version

Protocol Library	3 (Slave_Enhance_232_Library)
Protocol Version	4.6 ( 6.71.00)

### Manufacturer

Manufacturer ID	Product Type	Product ID
0x0060	0x000A	0x0002

### AGI (Association Group Information) Table

Group	Profile	Command Class & Command (List) N bytes	Group Name(UTF-8)
1	General	Notification Report Device Reset Locally Notification	Lifeline
2	Control	Basic Set	Basic Set

## Notification

Event	Type	Event	Event Parameters Length	Event Parameters
Program started	0x0C	0x01	null	
Program started Clear	0x0C	0x00	1 byte	0x01
Program completed	0x0C	0x03	null	
Program completed Clear	0x0C	0x00	1 byte	0x03
The power is applied for the first time	0x08	0x01	null	
The battery is Low	0x08	0x0A	null	

## Battery

Battery Report (value)	Description
0x64	Battery is high
0x10	Battery is normal
0x00	Battery is low

## Command Classes

- COMMAND\_CLASS\_ZWAVEPLUS\_INFO\_V2
- COMMAND\_CLASS\_ASSOCIATION\_V2 \*
- COMMAND\_CLASS\_ASSOCIATION\_GRP\_INFO \*
- COMMAND\_CLASS\_TRANSPORT\_SERVICE\_V2
- COMMAND\_CLASS\_VERSION\_V2 \*
- COMMAND\_CLASS\_MANUFACTURER\_SPECIFIC\_V2 \*
- COMMAND\_CLASS\_DEVICE\_RESET\_LOCALLY \*
- COMMAND\_CLASS\_POWERLEVEL\_V1 \*
- COMMAND\_CLASS\_BATTERY \*
- COMMAND\_CLASS\_SECURITY
- COMMAND\_CLASS\_SECURITY\_2
- COMMAND\_CLASS\_NOTIFICATION\_V8 \*
- COMMAND\_CLASS\_WAKE\_UP\_V2 \*
- COMMAND\_CLASS\_FIRMWARE\_UPDATE\_MD\_V4 \*

\*Items marked an asterisk are secure command classes.

### Wakeup Command Class

After it has been included into a Z-Wave network, the detector will go to sleep but will send a Wakeup Notification Command periodically at preset period to the controller. The detector will stay awake for 10 seconds at least and then go back to sleep to conserve battery life.

The time interval between Wakeup Notification Commands can be set in the Wakeup Command Class based on the range values below:

Minimum Wake Up Interval	600s (10 minutes)
Maximum Wake Up Interval	86400s (1 day)
Default Wake Up Interval	14400s (4 hours)
Wake Up Interval Step Seconds	600s (10 minutes)

## Troubleshooting

The table below lists the several steps involved when adding or removing the detector from the Z-Wave network.

Action/Status	Description	LED indication
No node ID	The Z-Wave Controller does not allocate a node	2-second on, 2-second off

	ID to the unit.	For 2 minutes
Auto Inclusion	The power is applied for the first time and no node ID has been stored in the module, or after executing reset.	
Manual Inclusion	1. Put the Z-Wave Controller into inclusion mode.	
	2. Press the link button 3 times within 1.5 seconds to put the unit into inclusion mode.	
Exclusion	1. Put the Z-Wave Controller into exclusion mode.	
	2. Press the link button 3 times within 1.5 seconds to put the unit into exclusion mode.	
Factory Reset (This procedure should only be used when the controller is inoperable.)	1. Press the link button 3 times within 1.5 seconds to put the unit into exclusion mode.	
	2. Within 1 second of step 1, press the link button again and hold for 5 seconds.	
	3. Node ID is excluded. The device reverts to factory default state.	2-second on, 2-second off For 2 minutes
× Failed or successful results in including/excluding the ID can be viewed on the Z-Wave Controller.		

Table below lists typical problems encountered:

Symptom	Possible Cause	Recommendation
Press Panic Button, LED illuminates, but the receiver(s) have no response	<ol style="list-style-type: none"> <li>Distance between the Panic Button and the receiver(s) too far</li> <li>Battery running low</li> <li>Receivers did not learn ID successfully</li> </ol>	<ol style="list-style-type: none"> <li>Move closer to the receivers</li> <li>Replace new batteries</li> <li>Bind with Gateway again</li> </ol>

## Specifications

Battery Type	AAA Battery x2
Battery Life	1 year*
Transmitting Range	Up to 100 meters line of sight
Frequency Range	EU: 868.42MHz US: 908.42 MHz JP: 922.5MHz
FCC ID	FU5AC136
IC	23210-AC136

**Specifications are subject to change without notice**

\*measured at 1 trigger per day



## Federal Communication Commission Interference Statement

This device complies with Part 15 of the FCC Rules. Operation is subject to the following two conditions: (1) This device may not cause harmful interference, and (2) this device must accept any interference received, including interference that may cause undesired operation.

This equipment has been tested and found to comply with the limits for a Class B digital device, pursuant to Part 15 of the FCC Rules. These limits are designed to provide reasonable protection against harmful interference in a residential installation. This equipment generates, uses and can radiate radio frequency energy and, if not installed and used in accordance with the instructions, may cause harmful interference to radio communications. However, there is no guarantee that interference will not occur in

a particular installation. If this equipment does cause harmful interference to radio or television reception, which can be determined by turning the equipment off and on, the user is encouraged to try to correct the interference by one of the following measures:

- Reorient or relocate the receiving antenna.
- Increase the separation between the equipment and receiver.
- Connect the equipment into an outlet on a circuit different from that to which the receiver is connected.
- Consult the dealer or an experienced radio/TV technician for help.

FCC Caution: Any changes or modifications not expressly approved by the party responsible for compliance could void the user's authority to operate this equipment.

This transmitter must not be co-located or operating in conjunction with any other antenna or transmitter.

## Radiation Exposure Statement:

This equipment complies with FCC radiation exposure limits set forth for an uncontrolled environment. This equipment should be installed and operated with minimum distance 20cm between the radiator & your body.

## Industry Canada statement:

This device complies with ISED's licence-exempt RSSs. Operation is subject to the following two conditions: (1) This device may not cause harmful interference, and (2) this device must accept any interference received, including interference that may cause undesired operation.

Le présent appareil est conforme aux CNR d'ISED applicables aux appareils radio exempts de licence. L'exploitation est autorisée aux deux conditions suivantes : (1) le dispositif ne doit pas produire de brouillage préjudiciable, et (2) ce dispositif doit accepter tout brouillage reçu, y compris un brouillage susceptible de provoquer un fonctionnement indésirable.

## Radiation Exposure Statement:

This equipment complies with ISED radiation exposure limits set forth for an uncontrolled environment. This equipment should be installed and operated with minimum distance 20cm between the radiator & your body.

## Déclaration d'exposition aux radiations:

Cet équipement est conforme aux limites d'exposition aux rayonnements ISED établies pour un environnement non contrôlé. Cet équipement doit être installé et utilisé avec un minimum de 20 cm de distance entre la source de rayonnement et votre corps.

## Warning:

Do not dispose of electrical appliances as unsorted municipal waste, use separate collection facilities. Contact your local government for information regarding the collection systems available. If electrical appliances are disposed of in landfills or dumps, hazardous substances can leak into the groundwater and get into the food chain, damaging your health and well-being. When replacing old appliances with new ones, the retailer is legally obligated to take back your old appliance for disposal at least for free of charge.



**EVERSPRING**  
www.everspring.com  
50 Sect. 1 Zhonghua Rd Tucheng  
NewTaipeiCity 236 Taiwan..

A501112653R01