



Aeon Labs Micro Smart Energy Switch

(In-Wall Z-Wave Appliance Module w/ Energy Monitor)



In-Wall Electrical Installation Instructions:

IMPORTANT: A licensed electrician with knowledge and understanding of electrical systems and electrical safety should complete the electrical installation inside the main circuit box (usually located outside of your house).

IMPORTANT: The electricity to the circuit must be shut off during installation for safety and to ensure that wires are not shortcircuited during installation which will cause damage to the Micro Module.

The Aeon Labs Micro Smart Energy Switch must first be powered by a 3-wire system in order to operate. The wiring diagram is as follows:

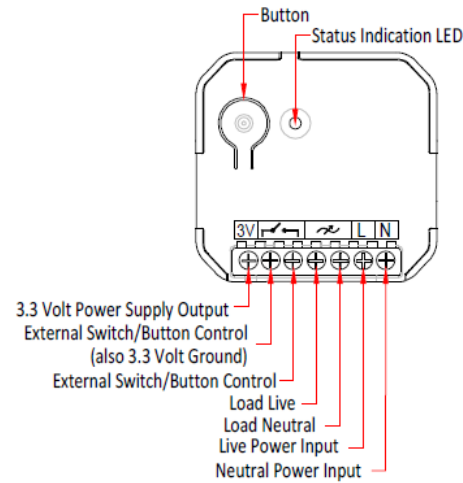

Z-Wave Network Instructions:

The Aeon Labs Micro Smart Energy Switch must be paired (included) into a Z-Wave network before it can receive Z-Wave commands to turn on/off and report its energy usage. The Smart Energy Switch can only communicate to devices within its own Z-Wave network.

Note: The LED on the Micro Smart Energy Switch will blink if it is currently not paired into a Z-Wave network.

• Adding/Including/Pairing the Micro Smart Energy Switch into a Z-Wave Network

1. Press the button labeled "Include" on the Aeon Labs Minimote to begin the Z-Wave inclusion process.

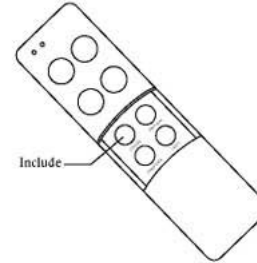

Note: To include the Aeon Labs Micro Smart Energy Switch with other controllers, please consult the operation manual for these controllers on how to include Z-Wave products into an existing network. For instructions on select partner gateways, visit www.aeon-labs.com/support.

2. While the Micro Smart Energy Switch is powered in a 3-wire system, press the button located near the Status Indication LED. Or alternatively, the external switch/button control can be pressed 6 times in quick succession.

Troubleshooting: If the Aeon Labs Micro Smart Energy Switch was not successfully included into any Z-Wave network, the LED will be blinking slowly continually. If the Aeon Labs Micro Smart Energy Switch was successfully included to a Z-Wave network, the Status Indication LED will either be solid on or off (depending on if the switch is on or off) 10 seconds after the button was last pressed.

• Removing/Resetting the Micro Smart Energy Switch from your Z-Wave Network

1. Press the button labeled "Remove" on the Aeon Labs Minimote Stick to begin the Z-Wave removal process.

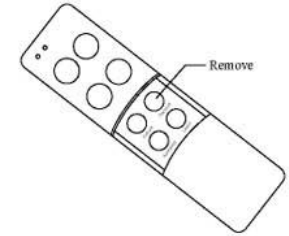

Note: To include the Aeon Labs Micro Smart Energy Switch with other controllers, please consult the operation manual for these controllers on how to include Z-Wave products into an existing network. For instructions on select partner gateways, visit www.aeon-labs.com/support.

2. While the Micro Smart Energy Switch is powered in a 3-wire system, press the button located near the Status Indication LED. Or alternatively, the external switch/button control can be pressed 6 times in quick succession.

Troubleshooting: If the Aeon Labs Micro Smart Energy Switch was removed from the Z-Wave network, the Status Indication LED will be blinking. If the Aeon Labs Smart Energy Switch was not successfully removed from the Z-Wave network, the Status Indication LED will either be solid on or off (depending on if the switch is on or off) 10 seconds after the button was last pressed.

• Turning On/Off the Micro Smart Energy Switch

Use any of the below methods to allow power through or cut power from the Micro Smart Energy Switch.

- Pressing the button on the external (Wall) switch will be able to toggle power flow (on/off) through the Smart Energy Switch.
- Through the usage of Z-Wave commands built into Z-Wave certified controllers and gateways. (The specific Z-Wave commands supporting this function are the Basic Command Class and Binary Switch Command Class.) Please consult the operation manual for these controllers for

specific instructions on controlling the Smart Energy Switch.

- Pressing the button on the Smart Energy Switch will toggle power flow (on/off) through the Smart Energy Switch.

option, to repair, replace or correct any such defect that was present at the time of delivery, or to remove the Products and to refund the purchase price to Customer.

The "Warranty Period" begins on the date the Products is delivered and continues for 12 months.

Any repairs under this warranty must be conducted by an authorized Aeon Labs service representative and under Aeon Labs' RMA policy. Any repairs conducted by unauthorized persons shall void this warranty.

Excluded from the warranty are problems due to accidents, acts of God, civil or military authority, civil disturbance, war, strikes, fires, other catastrophes, misuse, misapplication, storage damage, negligence, electrical power problems, or modification to the Products or its components.

Aeon Labs does not authorize any person or party to assume or create for it any other obligation or liability in connection with the Products except as set forth herein.

Aeon Labs will pass on to Customer all manufacturers' Material warranties to the extent that they are transferable, but will not independently warrant any Material.

Customer must prepay shipping and transportation charges for returned Products, and insure the shipment or accept the risk of loss or damage during such shipment and transportation. Aeon Labs will ship the repaired or replacement products to Customer freight prepaid.

Customer shall indemnify, defend, and hold Aeon Labs and Aeon Labs' affiliates, shareholders, directors, officers, employees, contractors, agents and other representatives harmless from all demands, claims, actions, causes of action, proceedings, suits, assessments, losses, damages, liabilities, settlements, judgments, fines, penalties, interest, costs and expenses (including fees and disbursements of counsel) of every kind (i) based upon personal injury or death or injury to property to the extent any of the foregoing is proximately caused either by a defective product (including strict liability in tort) or by the negligent or willful acts or omissions of Customer or its officers, employees, subcontractors or agents, and/or (ii) arising from or relating to any actual or alleged infringement or misappropriation of any patent, trademark, mask work, copyright, trade secret or any actual or alleged violation of any other intellectual property rights arising from or in connection with the

products, except to the extent that such infringement exists as a result of Aeon Labs' manufacturing processes.

IN NO EVENT SHALL AEON LABS BE LIABLE FOR ANY INDIRECT, INCIDENTAL, PUNITIVE, SPECIAL OR CONSEQUENTIAL DAMAGES, OR DAMAGES FOR LOSS OF PROFITS, REVENUE, OR USE INCURRED BY CUSTOMER OR ANY THIRD PARTY, WHETHER IN AN ACTION IN CONTRACT, OR TORT, OR OTHERWISE EVEN IF ADVISED OF THE POSSIBILITY OF SUCH DAMAGES. AEON LABS' LIABILITY AND CUSTOMER'S EXCLUSIVE REMEDY FOR ANY CAUSE OF ACTION ARISING IN CONNECTION WITH THIS AGREEMENT OR THE SALE OR USE OF THE PRODUCTS, WHETHER BASED ON NEGLIGENCE, STRICT LIABILITY, BREACH OF WARRANTY, BREACH OF AGREEMENT, OR EQUITABLE PRINCIPLES, IS EXPRESSLY LIMITED TO, AT AEON LABS' OPTION, REPLACEMENT OF, OR REPAYMENT OF THE PURCHASE PRICE FOR THAT PORTION OF PRODUCTS WITH RESPECT TO WHICH DAMAGES ARE CLAIMED. ALL CLAIMS OF ANY KIND ARISING IN CONNECTION WITH THIS AGREEMENT OR THE SALE OR USE OF PRODUCTS SHALL BE DEEMED WAIVED UNLESS MADE IN WRITING WITHIN THIRTY (30) DAYS FROM AEON LABS'S DELIVERY, OR THE DATE FIXED FOR DELIVERY IN THE EVENT OF NONDELIVERY.

THE INDEMNITY AND WARRANTY IN ABOVE ARE EXCLUSIVE AND IN LIEU OF ALL OTHER INDEMNITIES OR WARRANTIES, WHETHER EXPRESS OR IMPLIED, INCLUDING THE IMPLIED WARRANTIES OF MERCHANTABILITY AND FITNESS FOR A PARTICULAR PURPOSE.

FCC NOTICE (for USA):

THE MANUFACTURER IS NOT RESPONSIBLE FOR ANY RADIO OR TV INTERFERENCE CAUSED BY UNAUTHORIZED MODIFICATIONS TO THIS EQUIPMENT. SUCH MODIFICATIONS COULD VOID THE USER'S AUTHORITY TO OPERATE THE EQUIPMENT.

This device complies with Part 15 of the FCC Rules. Operation is subject to the following two conditions:

1. This device may not cause harmful interference, and
2. This device must accept any interference received, including interference that may cause undesired operation. This equipment has been tested and found to comply with the limits for a Class B digital device, pursuant to part 15 of the FCC Rules. These limits are designed to provide reasonable protection against

harmful interference in a residential installation. This equipment generates, uses and can radiate radio frequency energy and, if not installed and used in accordance with the instructions, may cause harmful interference to radio communications. However, there is no guarantee that interference will not occur in a particular installation. If this equipment does cause harmful interference to radio or television reception, which can be determined by turning the equipment off and on, the user is encouraged to try to correct the interference by one or more of the following measures:

- Reorient or relocate the receiving antenna.
- Increase the separation between the equipment and receiver.
- Connect the equipment into an outlet on a circuit different from that to which the receiver is connected.
- Consult the dealer or an experienced radio/TV technician for help.

Warning:

Do not dispose of electrical appliances as unsorted municipal waste, use separate collection facilities.

Contact your local government for information regarding the collection systems available.

Certifications (regional):



Harmonizing the Smart Home.

www.aeon-labs.com

Change Mode on the External Switch/Button Control

The Aeon Labs Micro Smart Energy Switch by default is set to be controlled via 2-state (flip/flop) external wall switch. Pushing the button 6 times in quick succession on the Micro Smart Energy Switch will swap between this default mode and the momentary push button external wall switch mode.

Monitoring Energy Consumption

The Aeon Labs Micro Smart Energy Switch can report wattage energy usage or kWh energy usage to a Z-Wave gateway or controller when requested. If this function is supported by the gateway/controller, the energy consumption will be displayed in the user interface of the gateway/controller. (The specific Z-Wave commands supporting energy monitoring are the Meter Command Class and Multilevel Sensor Command Class.) Please consult the operation manual for these gateways/controllers for specific instructions on monitoring the Smart Energy Switch.

Technical Specifications

- USA: 110V 60Hz input, 1100W or 10A max output
- EU/AU: 230V 50Hz input, 2300W or 10A max output

Warranty

Aeon Labs warrants to the original purchaser of Products that for the Warranty Period (as defined below), the Products will be free from material defects in materials and workmanship. The foregoing warranty is subject to the proper installation, operation and maintenance of the Products in accordance with installation instructions and the operating manual supplied to Customer. Warranty claims must be made by Customer in writing within thirty (30) days of the manifestation of a problem. Aeon Labs' sole obligation under the foregoing warranty is, at Aeon Labs'