

# FIBARO MOTION SENSOR FGMS-001

## CONTENTS

v2.0

#1: Description and features	4	#6: Association	10
#2: Basic activation	5	#7: Z-Wave range test	11
#3: Adding/removing the device	6	#8: Advanced parameters	12
#4: Physical installation	7	#9: Specifications	19
#5: Operating the device	8	#10: Guarantee	20



## Important safety information



### **Read this manual before attempting to install the device!**

Failure to observe recommendations included in this manual may be dangerous or cause a violation of the law. The manufacturer, Fibar Group S.A. will not be held responsible for any loss or damage resulting from not following the instructions of operating manual.

## General information about the FIBARO System

FIBARO is a wireless smart home automation system, based on the Z-Wave protocol. All of available devices can be controlled through a computer (PC or Mac), smartphone or tablet. Z-Wave devices are not only receivers, but can also repeat the signal, increasing the Z-Wave network's range. It gives advantage over traditional wireless systems that require direct link between transmitter and receiver, as a result the construction of the building could affect network's range negatively.

Every Z-Wave network has its unique identification number (home ID). Multiple independent networks can exist in the building without interfering. Transmission security of FIBARO System is comparable to wired systems.

Z-Wave technology is the leading solution in smart home automation. There is a wide range of Z-Wave devices that are mutually compatible, independently of manufacturer. It gives the system the ability to evolve and expand over time. For more information visit: [www.fibaro.com](http://www.fibaro.com).

## #1: Description and features

**FIBARO Motion Sensor** is a universal Z-Wave multi-sensor. Along with detecting motion the device measures the temperature and light intensity. The sensor has a built-in accelerometer to detect any tampering of the device. FIBARO Motion Sensor is battery powered device and designed to be installed quickly and easily on any surface. The LED indicator signals motion, temperature level, operating mode and can be used to see if device is within the Z-Wave network. The motion sensor can be used for lighting scenes and presence monitoring systems.

### NOTE

This device may be used with all devices certified with Z-Wave Plus certificate and should be compatible with such devices produced by other manufacturers.

### NOTE

FIBARO Motion Sensor is a Security Enabled Z-Wave Plus product and a Security Enabled Z-Wave Controller must be used in order to fully utilize the product.

### Main features of FIBARO Motion Sensor:

- compatible with any Z-Wave or Z-Wave+ Controller
- supports protected mode (Z-Wave network security mode) with AES-128 encryption
- detects motion using a passive IR sensor
- measures ambient temperature
- measures light intensity
- detects vibrations
- extremely easy installation
- may be installed anywhere - wall or any surface
- battery powered
- theft and tampering protection - once vibrations are detected, the notification is sent to the main controller
- detected movement, temperature and vibrations are signalled by the built-in LED diode



**FIBARO Motion Sensor is a fully compatible Z-Wave PLUS device.**

## #2: Basic activation

1. Turn the cover counter-clockwise and open it.

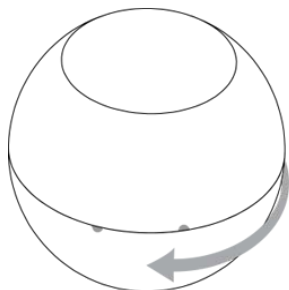

2. Remove the battery blocker.

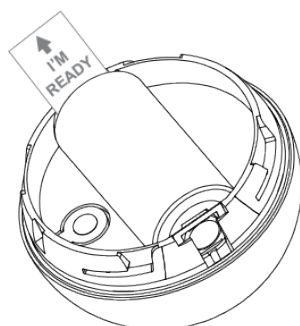

3. Add the device (see "Adding/removing the device" on page 6).
4. Wake up the sensor by triple clicking the B-button.

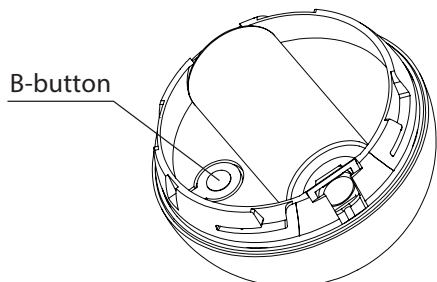

5. Close the cover and turn it clockwise.
6. Install the device (see "Physical installation" on page 7).

## #3: Adding/removing the device

### **i** NOTE

Adding in security mode must be performed up to 2 meters from the controller.

### **i** NOTE

In case the Sensor is not added, please reset the Sensor and repeat the adding procedure.

### **i** NOTE

Removing the device from the Z-Wave network restores all the default parameters of the device.

**Adding (Inclusion)** - Z-Wave device learning mode, allowing to add the device to existing Z-Wave network.

To add the device to the Z-Wave network:

1. Open the cover.
2. Place the Motion Sensor within the direct range of your Z-Wave controller.
3. Set the main controller in (security/non-security) add mode (see the controller's manual).
4. Quickly, three times press the B-button.

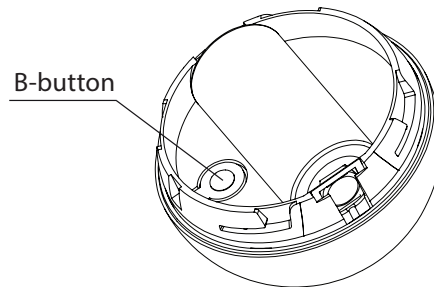

5. Wait for the adding process to end.
6. Successful adding will be confirmed by the Z-Wave controller's message.

**Removing (Exclusion)** - Z-Wave device learning mode, allowing to remove the device from existing Z-Wave network.

To remove the device from the Z-Wave network:

1. Open the cover.
2. Place the Motion Sensor within the direct range of your Z-Wave controller.
3. Set the main controller in remove mode (see the controller's manual).
4. Quickly, three times press the B-button.

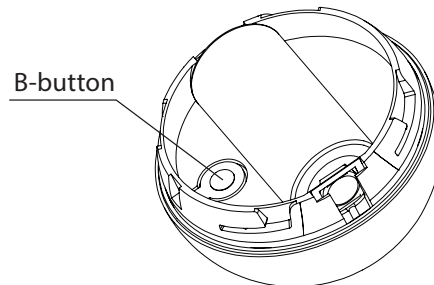

5. Wait for the removing process to end.
6. Successful removing will be confirmed by the Z-Wave controller's message.

## #4: Physical installation

### Detection range:

Detection range of the Motion Sensor is shown below. Actual range of the Sensor can be influenced by environmental conditions.

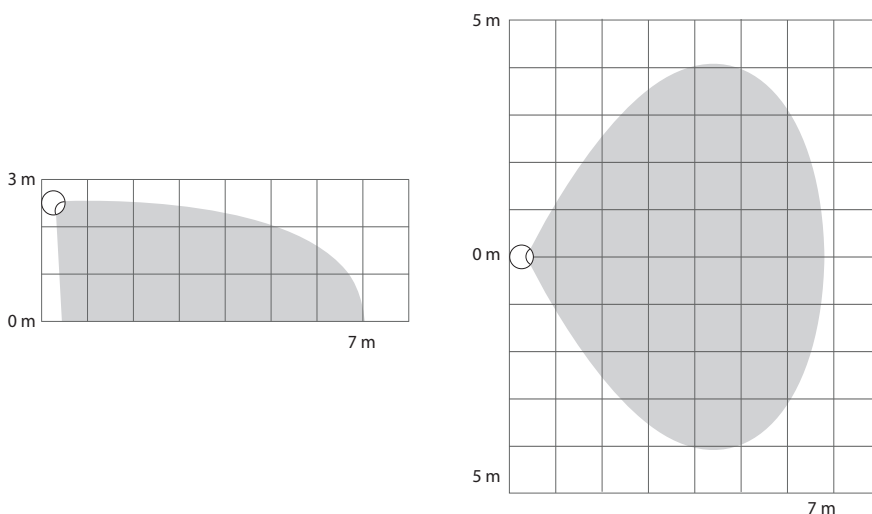

### Installation location and working conditions:

The Motion Sensor should be installed in a corner of the room or perpendicularly to the doors.

Moving objects such as trees blowing in the wind, cars passing by, windmills and moving masses of air and heat within detection area of the sensor can cause false motion detection.

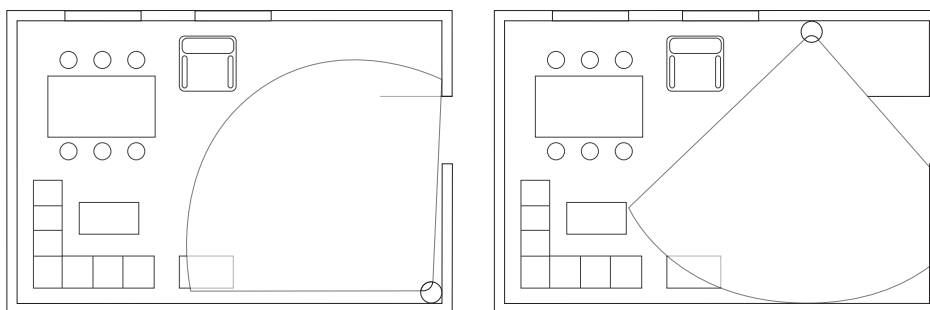

### Installing the Motion Sensor:

1. Install the holder (using an expansion bolt or a sticker).

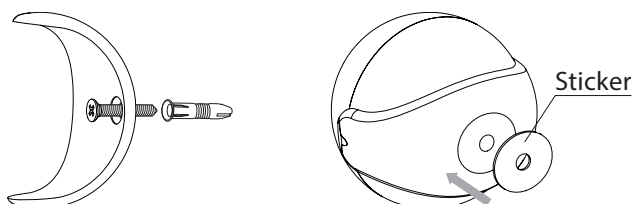

2. Insert the device into the holder.
3. Test the operation - check whether the device indicates motion detection.

### **i** NOTE

Remember to add the device to the Z-Wave network prior to installation, as the adding procedure must be performed within the direct range of the controller.

## #5: Operating the device

### Controlling the Motion Sensor using the B-button:

The Motion Sensor is equipped with a B-button, which allows to use the menu and additionally perform the following actions:

**1x click:** wake up the device or select the desired menu option (if menu is active)

**3x click:** add/remove the device to/from a Z-Wave network

**Holding:** enter/navigate through the menu

### Visual indications:

The Motion Sensor is equipped with a LED diode, signalling sensor's operating modes and alarms. In addition the visual indicator may inform of the Z-Wave network range and the current temperature.

Visual indicator signalling modes:

1. Motion Alarm colour will vary depending on the temperature. The colour and the signalling mode can be set in parameter 80.
2. Tamper alarm is signalled with an alternating blinking in LAPD colours (red - blue - white).
3. The Z-Wave Node Info command frame is signalled with glowing in blue. Node Info command frame is sent each time the device wakes up.
4. Menu position is signalled with assigned illumination colour.

### Menu:

Menu allows to perform Z-Wave network actions. In order to use the menu:

1. Press and hold the B-button.
2. Wait for the device to indicate desired position with a colour:
  - **VIOLET** - Z-Wave network's range test
  - **YELLOW** - device reset
3. Release the B-button.
4. Click the B-button to confirm selection.

### Waking up the Motion Sensor:

The Motion Sensor needs to be woken up to receive information on new configurations from the controller, like parameters and associations.

To wake up the sensor manually triple click the B-button located inside the housing.



## Controlling the Motion Sensor with FIBARO Home Center controller:

The Motion Sensor has a built-in motion detector, temperature sensor and light intensity sensor, which make it a multi-channel device. In the Home Center interface it will be presented as three devices.

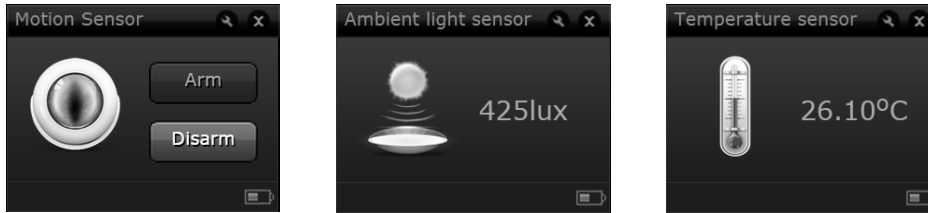

## Seismograph mode:

The Motion Sensor can be configured to work as a simple earthquake detector, by setting the parameter 24 value to 4. Reports with scale of the vibrations (in the Modified Mercalli Scale) will be sent at the time intervals specified in parameter 20. First report will be sent immediately after vibrations have been detected. Once the vibrations cease, reports will stop being sent.

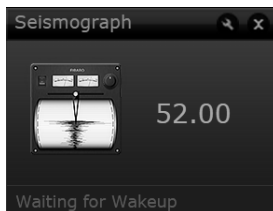

## Orientation in space:

The Motion Sensor has a built-in accelerometer. When the value of parameter 24 is set to 2 or 3, Z-Wave network controller will be informed on the Sensor's orientation in space by sending report after triggering tamper alarm.

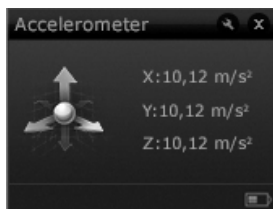

## Resetting the Motion Sensor:

Reset procedure erases the memory, including all information on the Z-Wave network and the main controller.

1. Open the cover.
2. Press and hold the B-button.
3. Wait for visual indicator to glow yellow (2nd menu position).
4. Release the B-button.
5. Click the B-button to confirm selection.
6. After few seconds the device will be reset, which is signalled with the red, fading visual indicator colour.

### **i** NOTE

Resetting the device is not the recommended way of removing the device from the Z-Wave network. Use reset procedure only if the primary controller is missing or inoperable. Certain device removal can be achieved by the procedure of removing described in "Adding/removing the device" on page 6.

## #6: Association

### **i** NOTE

Association allows direct transfer of control commands between devices, is performed without participation of the main controller and requires associated device to be in direct range.

**Association (linking devices)** - direct control of other devices within the Z-Wave system network e.g. Dimmer, Relay Switch, Roller Shutter or scene (may be controlled only through a Z-Wave controller).

#### **The Motion Sensor provides the association of four groups:**

**1st association group – “Lifeline”** reports the device status and allows for assigning single device only (main controller by default).

**2nd association group – “Motion”** is assigned to the motion sensor - sends motion detection and alarm cancellation frames to the associated devices.

**3rd association group – “Tamper”** is assigned to the tamper - sends tamper alarm and alarm cancellation frames to the associated devices.

**4th association group – “Motion BC”** is assigned to the motion sensor - sends motion detection and alarm cancellation frames to the associated devices. Provides backward compatibility with controllers not supporting Z-Wave+ protocol.

**4th association group – “Tamper BC”** is assigned to the tamper - sends tamper alarm and alarm cancellation frames to the associated devices. Provides backward compatibility with controllers not supporting Z-Wave+ protocol.

The Motion Sensor in 2nd to 5th group allows to control 5 regular and 5 multichannel devices per an association group, with the exception of “LifeLine” that is reserved solely for the controller and hence only 1 node can be assigned.

It is not recommended to associate more than 10 devices in general, as the response time to control commands depends on the number of associated devices. In extreme cases, system response may be delayed.

#### **To add an association** (using the Home Center controller):

1. Go to device options by clicking the icon: 
2. Select the „Advanced” tab.
3. Specify to which group and what devices are to be associated.
4. Wait for the configuration process to end. Sending relevant information to devices added to associated groups may take even a few minutes.
5. Wake up the device manually to speed up the configuration process.

## #7: Z-Wave range test

The Motion Sensor has a built in Z-Wave network main controller's **range tester**.

Follow the below instructions to test the main controller's range:

1. Open the cover.
2. Press and hold the B-button.
3. Wait for visual indicator to glow violet (1st menu position).
4. Release the B-button.
5. Click the B-button to confirm selection.
6. Visual indicator will indicate the Z-Wave network's range (range signalling modes described below).
7. To exit Z-Wave range test, press the B-button briefly.

### Z-Wave range tester signalling modes:

**Visual indicator pulsing green** - the Motion Sensor attempts to establish a direct communication with the main controller. If a direct communication attempt fails, the device will try to establish a routed communication, through other modules, which will be signalled by visual indicator pulsing yellow.

**Visual indicator glowing green** - the Motion Sensor communicates with the main controller directly.

**Visual indicator pulsing yellow** - the Motion Sensor tries to establish a routed communication with the main controller through other modules (repeaters).

**Visual indicator glowing yellow** - the Motion Sensor communicates with the main controller through the other modules. After 2 seconds the device will retry to establish a direct communication with the main controller, which will be signalled with visual indicator pulsing green.

**Visual indicator pulsing violet** - the Motion Sensor does communicate at the maximum distance of the Z-Wave network. If connection proves successful it will be confirmed with a yellow glow. It's not recommended to use the device at the range limit.

**Visual indicator glowing red** - the Motion Sensor is not able to connect to the main controller directly or through another Z-Wave network device (repeater).

### CAUTION

To make Z-Wave range test possible, the device must be added to the Z-Wave controller. Testing may stress the network, so it is recommended to perform the test only in special cases.

### NOTE

Communication mode of the Motion Sensor may switch between direct and one using routing, especially if the device is on the limit of the direct range.

## #8: Advanced parameters

The Motion Sensor allows to customize its operation to user's needs. The settings are available in the FIBARO interface as simple options that may be chosen by selecting the appropriate box.

In order to configure the Motion Sensor (using the Home Center controller):

1. Go to the device options by clicking the icon: 
2. Select the „Advanced” tab.

### Wake up interval

Available settings: **1-65535** (1-65535 seconds)

Default setting: **7200** (every 2 hours)

The Motion Sensor will wake up after each defined time interval and always try to connect with the main controller. After a successful communication attempt, the sensor will update configuration parameters, associations and settings and will go into standby mode. After failed communication attempt (e.g. lack of Z-Wave range) the device will go into standby mode and retry to establish connection with the main controller after the next time interval.

Wake up may be performed manually by a single B-button click.

Longer time interval means less frequent communication and thus a longer battery life.

### 1. Motion detection - sensitivity

The lower the value, the more sensitive the PIR sensor is.

Available settings:	<b>8-255</b>		
Default setting:	<b>15</b>	Parameter size:	<b>2</b> [bytes]

### 2. Motion detection - blind time

PIR sensor is “blind” (insensitive) to motion after last detection for the amount of time specified in this parameter.

Shorter time periods allow to detect motion more frequently, but the battery will be drained faster.

Available settings:	<b>0-15</b> (0.5-8 seconds, time [s] = 0.5 x (value+1))		
Default setting:	<b>3</b>	Parameter size:	<b>1</b> [byte]

#### NOTE

Blind time should be shorter than the time period set in parameter 6 (alarm cancellation delay).

### 3. Motion detection - pulse counter

This parameter determines the number of moves required for the PIR sensor to report motion. The higher the value, the less sensitive the PIR sensor is.

It is not recommended to modify this parameter settings!

Available settings:	<b>0</b> - 1 pulse <b>1</b> - 2 pulses <b>2</b> - 3 pulses <b>3</b> - 4 pulses		
Default setting:	<b>1</b> (2 pulses)	Parameter size:	<b>1</b> [byte]

### 4. Motion detection - window time

Period of time during which the number of moves set in parameter 3 must be detected in order for the PIR sensor to report motion. The higher the value, the more sensitive the PIR sensor is.

It is not recommended to modify this parameter setting!

Available settings:	<b>0</b> - 4 seconds <b>1</b> - 8 seconds <b>2</b> - 12 seconds <b>3</b> - 16 seconds		
Default setting:	<b>2</b> (12seconds)	Parameter size:	<b>1</b> [byte]

### 6. Motion detection - alarm cancellation delay

Time period after which the motion alarm will be cancelled in the main controller and associated devices.

Any motion detected during this period resets the timer.

Available settings:	<b>1-32767</b> (in seconds)		
Default setting:	<b>30</b> (30s)	Parameter size:	<b>2</b> [bytes]

### 8. Motion detection - operating mode

This parameter determines in which part of day the PIR sensor will be active.

This parameter influences only the motion reports and associations. Tamper, light intensity and temperature measurements will be still active, regardless of this parameter settings.

Available settings:	<b>0</b> - PIR sensor always active <b>1</b> - PIR sensor active during the day only <b>2</b> - PIR sensor active during the night only		
Default setting:	<b>0</b>	Parameter size:	<b>1</b> [byte]

**i** NOTE

Values of BASIC ON and BASIC OFF command frames can be modified with dedicated parameters (14 and 16).

### 9. Motion detection - night/day

This parameter defines the difference between night and day in terms of light intensity, used in parameter 8.

Available settings:	<b>1-32767</b> (1-32767 lux)		
Default setting:	<b>200</b> (200 lux)	Parameter size:	<b>2</b> [bytes]

### 12. BASIC command class configuration

This parameter determines the command frames sent to 2nd association group (assigned to PIR sensor).

Available settings:	<b>0</b> - BASIC ON and OFF command frames sent in Basic Command Class <b>1</b> - only the BASIC ON command frame sent in Basic Command Class <b>2</b> - only the BASIC OFF command frame sent in Basic Command Class		
Default setting:	<b>0</b>	Parameter size:	<b>1</b> [byte]

### 14. BASIC ON command frame value

The command frame sent at the moment of motion detection. Further motion detections, during the cancellation time, will not result in sending the association.

Available settings:	<b>0-255</b>		
Default setting:	<b>255</b>	Parameter size:	<b>2</b> [byte]

### 16. BASIC OFF command frame value

The command frame sent at the moment of motion alarm cancellation, after cancellation delay time specified in parameter 6.

Available settings:	<b>0-255</b>		
Default setting:	<b>0</b>	Parameter size:	<b>2</b> [bytes]

### 18. Associations in Z-Wave network Security Mode

This parameter defines how commands are sent in specified association groups: as secure or non-secure. Parameter is active only in Z-Wave network security mode. It does not apply to 1st group "Lifeline".

Available settings:	<b>0</b> - none of the groups sent as secure <b>1</b> - 2nd group sent as secure <b>2</b> - 3rd group sent as secure <b>4</b> - 4th group sent as secure <b>8</b> - 5th group sent as secure		
Default setting:	<b>0-15</b>	Parameter size:	<b>1</b> [byte]

## 20. Tamper - sensitivity

This parameter determines the change in force acting on the device, that will result in reporting tamper alarm - g-force acceleration.

Available settings:	<b>0</b> - tamper inactive <b>1-121</b> - (0.08-2g; every 0.016g)		
Default setting:	<b>20</b> (0.4g)	Parameter size:	<b>1</b> [byte]

## 22. Tamper - alarm cancellation delay

Time period after which a tamper alarm will be cancelled in the main controller and associated devices.

Any tampering detected during this period will not extend the delay.

Available settings:	<b>1-32767</b> (in seconds)		
Default setting:	<b>30</b> (30s)	Parameter size:	<b>2</b> [bytes]

## 24. Tamper - operating modes

This parameter determines function of the tamper and sent reports. It is an advanced feature serving much more functions than just detection of tampering.

Available settings:	<b>0</b> - tamper only <b>1</b> - tamper and earthquake detector <b>2</b> - tamper and orientation in space		
Default setting:	<b>0</b>	Parameter size:	<b>1</b> [byte]

## 25. Tamper - alarm cancellation

This parameter allows to disable cancellation of the tamper alarm.

Available settings:	<b>0</b> - do not send tamper cancellation report <b>1</b> - send tamper cancellation report		
Default setting:	<b>1</b>	Parameter size:	<b>1</b> [byte]

## 28. Tamper - broadcast mode

The parameter determines whether the tamper alarm frame will or will not be sent in broadcast mode. Alarm frames sent in broadcast mode can be received by all of the devices within range (if they accept such frames), but not repeated by them.

Available settings:	<b>0</b> - tamper alarm sent to 3rd association group <b>1</b> - tamper alarm sent in broadcast mode		
Default setting:	<b>0</b>	Parameter size:	<b>1</b> [byte]

## 29. Tamper - backward compatible broadcast mode

The parameter determines whether the backward compatible tamper alarm frame will or will not be sent in broadcast mode. Alarm frames sent in broadcast mode can be received by all of the devices within range (if they accept such frames), but not repeated by them.

### **i** NOTE

Device operating in Security Mode does not send frames in broadcast mode. In this case leave the default values of parameters 28 and 29.

This parameter provides backward compatibility with controllers not supporting Z-Wave+.

Available settings:	<b>0</b> - backward compatible tamper alarm sent to 5th association group <b>1</b> - backward compatible tamper alarm sent in broadcast mode		
Default setting:	<b>0</b>	Parameter size:	<b>1</b> [byte]

**40. Illuminance report - threshold**

This parameter determines the change in light intensity level resulting in illuminance report being sent to the main controller.

Available settings:	<b>0</b> - reports are not sent <b>1-32767</b> (illuminance in lux)		
Default setting:	<b>200</b> (200 lux)	Parameter size:	<b>2</b> [bytes]

**i** NOTE

Frequent illuminance reports will shorten the battery life. Parameter value under 5 may result in blocking the temperature reports.

**42. Illuminance report - interval**

Time interval between consecutive illuminance reports. The reports are sent even if there is no change in the light intensity.

Available settings:	<b>0</b> - periodical reports are not sent <b>1-32767</b> (in seconds)		
Default setting:	<b>3600</b> (1h)	Parameter size:	<b>2</b> [bytes]

**60. Temperature report - threshold**

This parameter determines the change in measured temperature that will result in new temperature report being sent to the main controller.

Available settings:	<b>0</b> - reports are not sent <b>1-255</b> (0.1-25.5°C, 0.1°C step)		
Default setting:	<b>20</b> (1°C)	Parameter size:	<b>2</b> [bytes]

**i** NOTE

Temperature measurements are still performed during the wake up, even if the periodic measuring is disabled (parameter 62 set to 0).

**62. Temperature measuring - interval**

Time interval between consecutive temperature measurements. The shorter the time, the more frequently the temperature will be measured, but the battery life will shorten.

Available settings:	<b>0</b> - temperature is not measured <b>1-32767</b> (in seconds)		
Default setting:	<b>900</b> (900s)	Parameter size:	<b>2</b> [bytes]

**i** NOTE

Frequent temperature reports will shorten the battery life. Parameter value under 5 may result in blocking the illuminance reports.

**64. Temperature report - interval**

Time interval between consecutive temperature reports. The reports are sent even if there is no change in the temperature.

Available settings:	<b>0</b> - periodical reports are not sent <b>1-32767</b> (in seconds)		
Default setting:	<b>0</b>	Parameter size:	<b>2</b> [bytes]



## 66. Temperature offset

The value to be added to the actual temperature, measured by the sensor (temperature compensation).

Available settings:	<b>-1000-1000</b> (-1000-1000°C, 1°C step)		
Default setting:	<b>0</b> (0°C)	Parameter size:	<b>2</b> [bytes]

## 80. Visual LED indicator - signalling mode

This parameter determines the way in which visual indicator behaves after motion has been detected.

Available settings:	<p><b>0</b> - LED inactive,</p> <p>Values from <b>1 to 9</b> - single long blink at the moment of reporting motion. No other motion will be indicated until alarm is cancelled.</p> <p><b>1</b> - colour is temperature dependent, <b>2</b> - Flashlight Mode, <b>3</b> - white, <b>4</b> - red, <b>5</b> - green, <b>6</b> - blue, <b>7</b> - yellow, <b>8</b> - cyan, <b>9</b> - magenta</p> <p>Values from <b>10 to 18</b> - single long blink at the moment of reporting motion and one short blink each time the motion is detected again.</p> <p><b>10</b> - colour is temperature dependent, <b>11</b> - Flashlight Mode, <b>12</b> - white, <b>13</b> - red, <b>14</b> - green, <b>15</b> - blue, <b>16</b> - yellow, <b>17</b> - cyan, <b>18</b> - magenta</p> <p>Values from <b>19 to 26</b> - single long blink at the moment of reporting motion and two short blinks each time the motion is detected again.</p> <p><b>19</b> - colour is temperature dependent, <b>20</b> - white, <b>21</b> - red, <b>22</b> - green, <b>23</b> - blue, <b>24</b> - yellow, <b>25</b> - cyan, <b>26</b> - magenta</p>		
Default setting:	<b>10</b>	Parameter size:	<b>1</b> [byte]

## 81. Visual LED indicator - brightness

This parameter determines the brightness of the visual LED indicator when indicating motion.

Available settings:	<p><b>0</b> - brightness determined by the illuminance (parameters 82 and 83)</p> <p><b>1-100</b> (1-100%)</p>		
Default setting:	<b>50</b> (50%)	Parameter size:	<b>1</b> [byte]

## 82. Visual LED indicator - illuminance for low indicator brightness

Light intensity level below which brightness of visual indicator is set to 1%.

Available settings:	<b>0 to value of parameter 83</b> (in lux)		
Default setting:	<b>100</b>	Parameter size:	<b>2</b> [bytes]

### NOTE

Flashlight Mode - visual indicator glows in white for 10 seconds. If value of parameter 80 is set to 11, each detected motion extends the glowing by next 10 seconds.

### CAUTION

The value of parameter 83 must be higher than the value of parameter 82.

**83. Visual LED indicator - illuminance for high indicator brightness**

Light intensity level above which brightness of visual indicator is set to 100%.

Available settings:	<b>value of parameter 82 to 32767</b> (in lux)		
Default setting:	<b>1000</b>	Parameter size:	<b>2</b> [bytes]

**86. Visual LED indicator - temperature for blue colour**

This parameter is determines minimal temperature that will result in blue visual indicator colour. Relevant only when parameter 80 has been properly configured.

Available settings:	<b>0 to value of parameter 87</b> (in Celsius degree)		
Default setting:	<b>18</b> (18°C)	Parameter size:	<b>2</b> [bytes]

**87. Visual LED indicator - temperature for red colour**

This parameter is determines minimal temperature that will result in red visual indicator colour. Relevant only when parameter 80 has been properly configured.

Available settings:	<b>value of parameter 86 to 255</b> (in Celsius degree)		
Default setting:	<b>28</b> (28°C)	Parameter size:	<b>2</b> [bytes]

**89. Visual LED indicator - tamper alarm**

This parameter allows to enable/disable indicating tamper alarm (flashing white, red and blue)

Available settings:	<b>0</b> - tamper alarm is not indicated <b>1</b> - tamper alarm is indicated		
Default setting:	<b>1</b>	Parameter size:	<b>1</b> [byte]

## #9: Specifications

Power supply:	3.0V DC battery
Battery type:	CR123A
EU directives compliance:	EMC 2004/108/EC R&TTE 1999/5/EC RoHS 2011/65/EU LVD 2006/95/EC
Radio protocol:	Z-Wave
Radio frequency:	868.4 or 869.8 MHz EU; 908.4 or 916.0 MHz US; 921.4 or 919.8 MHz ANZ; 869.0 MHz RU;
Range:	up to 50m outdoors up to 40m indoors (depending on terrain and building structure)
Recommended installation height:	2.4 meters
Operating temperature:	0-40°C
Temperature measuring range:	-20-100°C
Temperature measuring accuracy:	0.5°C (within 0-40°C range)
Illuminance measuring range:	0-32000 lux
Dimensions (diameter):	76 x 17 x 19 mm

## #10: Guarantee

1. The Guarantee is provided by FIBAR GROUP S.A. (hereinafter „Manufacturer“), based in Poznan, ul. Lotnicza 1; 60-421 Poznan, entered in the register of the National Court Register kept by the District Court in Poznań, VIII Economic Department of the National Court Register, no. 553265, NIP 7811858097, REGON: 301595664.

2. The Manufacturer is responsible for equipment malfunction resulting from physical defects (manufacturing or material) of the Device during 12 months for business / 24 months for individual customers from the date of its purchase.

3. During the Guarantee period, the Manufacturer shall remove any defects, free of charge, by repairing or replacing (at the sole discretion of the Manufacturer) any defective components of the Device with new or regenerated components that are free from defects. When the repair proves impossible, the Manufacturer reserves the right to replace the device with a new or regenerated one, which shall be free from any defects and its condition shall not be worse than the original device owned by the Customer.

4. In special cases, when the device cannot be replaced with the device of the same type (e.g. the device is no longer available), the Manufacturer may replace it with a different device having technical parameters similar to the faulty one. Such activity shall be considered as fulfilling the obligations of the Manufacturer. The Manufacturer shall not refund money paid for the device.

5. The holder of a valid guarantee shall submit a guarantee claim through the guarantee service. Remember: before you submit a guarantee claim, contact our technical support using telephone or e-mail. More than 50% of operational problems are resolved remotely, saving time and money spent to initiating guarantee procedure. If remote support is insufficient, the Customer shall fill the guarantee claim form (using our website - [www.fibaro.com](http://www.fibaro.com)) in order to obtain claim authorization. When the guarantee claim form is submitted correctly, the Customer shall receive the claim confirmation with a unique number (Return Merchandise Authorization -RMA).

6. The claim may be also submitted by telephone. In this case, the call is recorded and the Customer shall be informed about it by a consultant before submitting the claim. Immediately after submitting the claim, the consultant shall provide the Customer with the claim number (RMA-number).

7. When the guarantee claim form is submitted correctly, a representative of the Authorised Guarantee Service (hereinafter as „AGS“) shall contact the Customer.

8. Defects revealed within the guarantee period shall be removed not later than 30 days from the date of delivering the Device to AGS. The guarantee period shall be extended by the time in which the Device was kept by AGS.

9. A faulty device shall be provided by the Customer with complete standard equipment and documents proving its purchase.

10. Parts replaced under the guarantee are the property of the Manufacturer. The guarantee for all parts replaced in the guarantee process shall be equal to the guarantee period of the original device. The guarantee period of the replaced part shall not be extended.

11. Costs of delivering the faulty device shall be borne by the Customer. For unjustified service calls, the Service may charge the Customer with travel expenses and handling costs related to the case.

12. AGS shall not accept a complaint claim only when:

- the Device was misused or the manual was not observed,
- the Device was provided by the Customer incomplete, without accessories or nameplate,
- it was determined that the fault was caused by other reasons than a material or manufacturing defect of the Device
- the guarantee document is not valid or there is no proof of purchase,

13. The Manufacturer shall not be liable for damage to property caused by defective device. The Manufacturer shall not be liable for indirect, incidental, special, consequential or punitive damage, or for any damage, including, inter alia, loss of profits, savings, data, loss of benefits, claims by third parties and any property damage or personal injuries arising from or related to the use of the Device.

14. The guarantee shall not cover:

- mechanical damage (cracks, fractures, cuts, abrasions, physical deformations caused by impact, falling or dropping the device or other object, improper use or not observing the operating manual);
- damage resulting from external causes, e.g.: flood, storm, fire, lightning, natural disasters, earthquakes, war, civil disturbance, force majeure, unforeseen accidents, theft, water damage, liquid leakage, battery spill, weather conditions, sunlight, sand, moisture, high or low temperature, air pollution;
- damage caused by malfunctioning software, attack of a computer virus, or by failure to update the software as recommended by the Manufacturer;
- damage resulting from: surges in power supply and/or telecommunication network, improper connection to the grid in a manner inconsistent with the operating manual, or from connecting other devices not recommended by the Manufacturer.
- damage caused by operating or storing the device in extremely adverse conditions, i.e. high humidity, dust, too low (freezing) or too high ambient temperature. Detailed permissible conditions for operating the Device are defined in the operating manual;
- damage caused by using accessories not recommended by the Manufacturer
- damage caused by faulty electrical installation of the Customer, including the use of incorrect fuses;
- damage caused by Customer's failure to provide maintenance and servicing activities defined in the operating manual;
- damage resulting from the use of spurious spare parts or accessories improper for given model, repairing and introducing alterations by unauthorized persons;
- defects caused by operating faulty Device or accessories.

15. The scope of the guarantee repairs shall not include periodic maintenance and inspections, in particular cleaning, adjustments, operational checks, correction of errors or parameter programming and other activities that should be performed by the user (Buyer). The guarantee shall not cover natural wear and tear of the Device and its components listed in the operating manual and in technical documentation as such elements have a defined operational life.

16. If a defect is not covered by the guarantee, the Manufacturer reserves the right to remove such defect at its sole discretion, repairing the damaged or destroyed parts or providing components necessary for repair or replacement.

17. This guarantee shall not exclude, limit or suspend the Customer rights when the provided product is inconsistent with the purchase agreement.