

SP815

PET IMMUNE PIR MOTION DETECTOR

The SP815 is a multifunction device with motion detector and temperature/humidity sensor. It uses Passive Infra-Red (PIR) technology to detect movement in a protected area by sensing the changes of thermal radiation caused by the moving body within or across the field of detection. Featuring dual PIR sensor designed with dual lens technology, this detector is immune to presence of pets in the home allowing your pet to move freely without causing false alarms.

This product is a Z-Wave Plus enabled device and is fully compatible with any Z-Wave enabled network. The device can be set up in a Z-Wave network to communicate directly with other end devices such as smartplugs, or to report directly to a Z-Wave controller (usually a gateway).

When the motion detector is triggered, an alarm signal will be emitted to the controller and the controller, after receiving the signal, will perform certain action according to its settings.

The product has a built in digital temperature sensor and humidity sensor to report environmental condition of the protected area to the controller.

This product supports the S2 security protocol that uses encrypted Z-Wave Plus messages to communicate to other security-enabled Z-Wave Plus products. A security-enabled Z-Wave Plus Controller must be used in order to fully utilize the security features of this product.

Product Overview

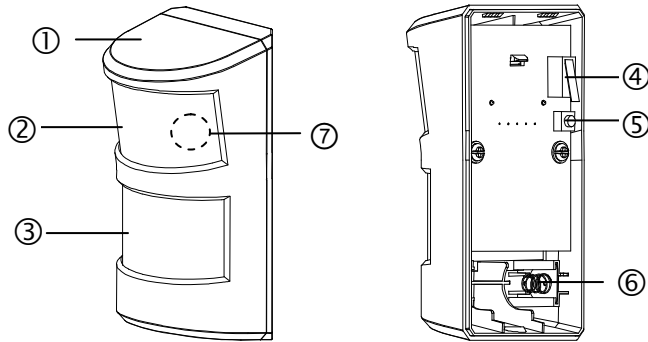

(rear cover removed)

① Front Cover	② Upper Lens	③ Lower Lens
④ Tamper button	⑤ Learn Key	⑥ Battery Compartment
⑦ LED indicator (hidden behind lens)		

Adding to Z-Wave Network

Auto Inclusion

The detector supports Auto Inclusion feature where it will automatically enter Inclusion mode when first powered up after a factory reset.

1. Undo and remove the fixing screw located at the bottom of the PIR detector. Then carefully open the rear cover.

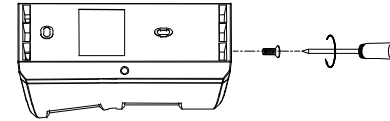

2. Prepare the Z-wave Controller for Inclusion.
3. Insert the battery into the battery compartment. Note the correct polarity of battery as indicated.

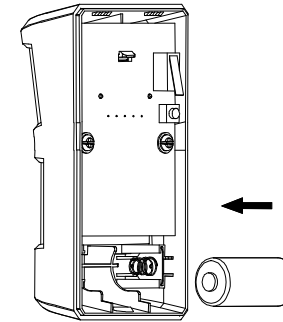

4. The LED on the device will turn on. The duration of inclusion mode is 30 seconds.
5. The Inclusion process should be completed when the LED stops blinking.

Note:

If you are connecting this unit to a Z-Wave Controller that utilizes the S2 security protocol, you may be asked by your controller to enter a 5-digit Device Specific Key (DSK) that is unique to each unit. This can be found in one of two places:

- on the QR code label on the back of the unit
- on the insert card inside the packaging.

If Auto Inclusion fails, refer to the Troubleshooting section regarding Manual Inclusion.

Testing

Warm-Up

It will take approximately 1 minute for the detector to warm up after the battery is inserted. During this period the LED behind the lens will turn on. When the LED turns off, it implies warm-up procedure is complete and the detector is ready for detection.

Note:

- This will not affect the Inclusion/Exclusion process.
- After removing batteries, wait for 5 seconds to refit batteries.

Quick Test

1. With the tamper switch not being pressed, the unit will enter Test mode to allow the user to test the device before it is mounted on the wall.
2. During Test mode, if movement is detected, the LED on the detector will illuminate implying the unit is working properly. Wait for 5 seconds before the next detection test.

To exit the Test mode, simply press the Tamper switch for more than 10 seconds to enter Normal mode.

Mounting the Detector

Choosing a location

The detector is suitable for mounting indoor in dry interior locations only.

When considering a location for the detector the following points should be considered:

- Do not locate the detector facing a window or where it is exposed to or facing direct sunlight. PIR detectors are not suitable for use in conservatories.
- Do not locate the detector where it is exposed to ventilators.
- Do not locate the detector directly above a heat source, (e.g. fire, radiator, boiler, etc).
- Do not locate the detector in a position where it is subject to excessive vibration.

Where possible, mount the detector in the corner of the room so that the logical path of an intruder would cut across the detection zone. PIR detectors respond more effectively to movement across the detection area than to movement directly towards the sensor.

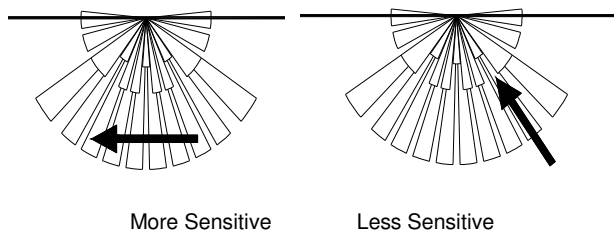

The detector can be installed on a flat wall or in a corner as shown below.

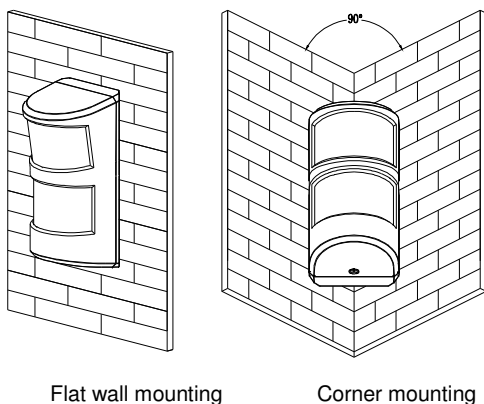

Mount the PIR detector at height of 2m. At this height, the detector will optimize the detection range of up to 12m with a field of view of 90°.

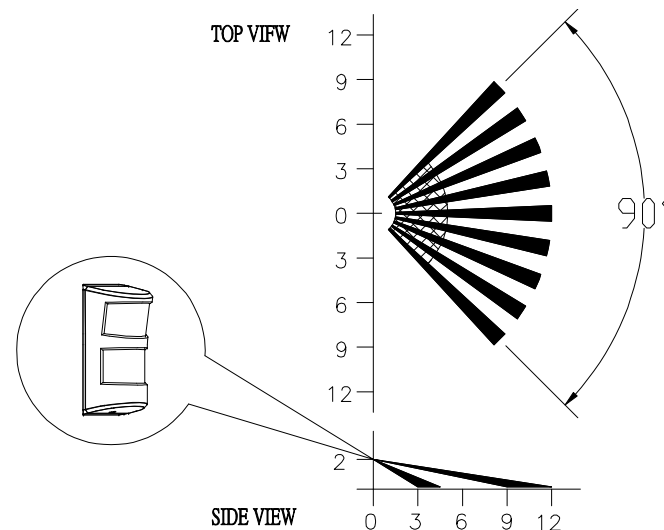

This product comes with pet immunity mechanism so that small pets or animals will not trigger the detector and cause false alarms. For pet immunity to be effective the pet's height and length must not exceed 60cm/90cm respectively to avoid triggering the detector.

Note:

If the height of your pet exceeds 60cm, you can mount the PIR detector higher to prevent the PIR from being triggered by your pet. For example, if your pet is 70cm tall, you can mount the detector at the height of 2.1m instead of 2m as in regular condition, and the 70cm-tall pet should be able to stroll by without triggering the PIR. However, the same effect would also apply to human detection. So the PIR detector should not be mounted too high to affect its regular detection purpose.

Installation

1. Remove the rear cover if it is fixed to the main body (refer to Figure 3). Use the rear cover as a template to mark the positions of the fixing holes on the wall. Carefully drill the required mounting holes on the wall.

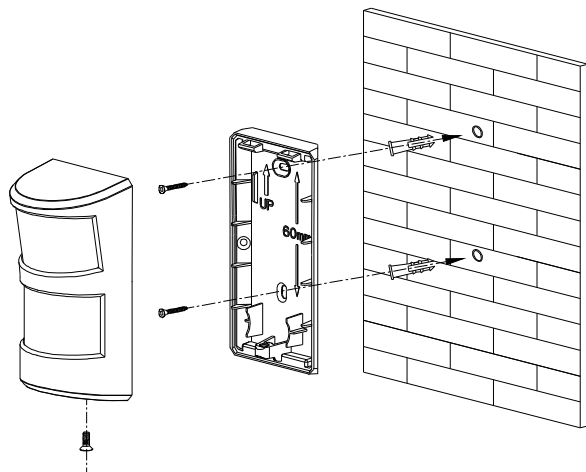

2. Fix the rear cover to the wall using the supplied screws and wall plugs. Do not over-tighten the fixing screws as this may distort or damage the cover.
3. Replace the main body to the rear cover and refit the fixing screw in the bottom of the PIR to secure the main body. Do not over-tighten the fixing screw as this may damage the casing.

Operation

When the detector is mounted on the wall i.e. tamper switch is pressed for more than 10 seconds, it will enter Normal mode.

- Upon motion being detected, the detector will send an alert signal to the controller and enter sleep state for a preset period to conserve battery life. It will only be able to detect motion again when this preset period is up. This preset period is called Retrigger Interval and can be set by the controller. The default period is 3 minutes.

- Unlike in Test mode, the red indicator LED on the detector will not illuminate when triggered in order to conserve battery life.

The detector can provide periodic auto report measurement of temperature and humidity to the controller, or on demand when requested by the controller.

In the event its front cover is removed, the tamper switch will be activated and the detector will send a Notification command to the controller.

Maintenance

Low Battery: Under low battery condition, the detector will remit RF signals to the Z-Wave controller to alert the user of its low battery condition. Replace the batteries as soon as possible.

Programming

Z-Wave Group

The PIR detector supports 2 Association Groups:

Group 1: Association with 1 Controller node.

Group 1 command:

- When the unit is powered up or the tamper is triggered, the unit will send a Notification Report to the node of Group 1.
- When the battery level of the unit drops to an unacceptable level, the unit will emit Battery report to the nodes of Group 1.
- When performing Factory Reset the unit will send Device Reset Locally Notification to the node of Group1.
- The unit will send Multilevel Sensor Report to the node of Group 1.

Group 2: Association with 4 nodes (i.e. end devices such as smart plugs and other lighting controllers). This allows the detector to transfer commands directly to end devices without the participation of the controller. This has the effect that when the detector triggers, all devices associated with detector will be operated.

Group 2 commands:

- When the detector is triggered, the unit will send BASIC_SET ON/OFF command which contains a value to the nodes of Group 2.

Z-Wave Plus Info

Role Type	Node Type	Installer Icon	User Icon
Slave Sleeping Listening	Z-Wave Plus node	Sensor Notification Device Type (Home Security)	Sensor Notification Device Type (Home Security)

Association Command Class

Group	Max Node
1	1
2	4

Version

Protocol Library	3 (Slave_Enhance_232_Library)
Protocol Version	4.3D (6.71.01)

Manufacturer

Manufacturer ID	Product Type	Product ID
0x0060	0x0001	0x0004

AGI (Association Group Information) Table

Group	Profile	Command Class & Command (List) N bytes	Group Name(UTF-8)
1	General	Battery Report, Device Reset Locally Notification, Notification Report	Lifeline
2	Control	Basic Set	PIR Control

Notification

Event	Type	Event	Event Parameter Length	Event Parameter
The power is applied for the first time	0x08	0x01	0x00	
PIR Trigger ON	0x07	0x08	0x00	
PIR Trigger OFF	0x07	0x00	0x01	0x08
Tamper switch being press more than 10 seconds	0x07	0x00	0x01	0x03

Tamper switch being press more than 10 seconds and released	0x07	0x03	0x00	
---	------	------	------	--

Battery

Battery Report (value)	Description
20~100	Battery Level %
0xFF	Low Battery

Sensor Multilevel Get

Sensor Type	Scale	
0x01	0x00	Temperature (°C)
0x05	0x00	Humidity

Command Classes

The module supports Command Classes including...

- COMMAND_CLASS_ZWAVEPLUS_INFO_V2
- COMMAND_CLASS_ASSOCIATION_V2*
- COMMAND_CLASS_ASSOCIATION_GRP_INFO*
- COMMAND_CLASS_TRANSPORT_SERVICE_V2
- COMMAND_CLASS_VERSION_V2*
- COMMAND_CLASS_MANUFACTURER_SPECIFIC_V2*
- COMMAND_CLASS_DEVICE_RESET_LOCALLY*
- COMMAND_CLASS_POWERLEVEL*
- COMMAND_CLASS_SECURITY
- COMMAND_CLASS_SECURITY_2
- COMMAND_CLASS_SUPERVISION*
- COMMAND_CLASS_FIRMWARE_UPDATE_MD_V2*
- COMMAND_CLASS_BATTERY*
- COMMAND_CLASS_NOTIFICATION_V4*
- COMMAND_CLASS_WAKE_UP*
- COMMAND_CLASS_CONFIGURATION*
- COMMAND_CLASS_SENSOR_MULTILEVEL*

*Items marked an asterisk are secure command classes.

Wakeup Command Class

After it has been included into a Z-Wave network, the detector will go to sleep but will send a Wakeup Notification Command periodically at preset period to the controller. The Motion detector will stay awake for 10 seconds at least and then go back to sleep to conserve battery life.

The time interval between Wakeup Notification Commands can be set in the Wakeup Command Class based on the range values below:

Minimum Wake Up Interval	600s (10 minutes)
Maximum Wake Up Interval	86400s (1 day)
Default Wake Up Interval	14400s (4 hours)
Wake Up Interval Step Seconds	600s (10 minutes)

Z-Wave Configuration

- Temperature & Humidity Auto Report period setting

Parameter Number	Size	Range	Default
1	2	0~1440(sec)	30mins (0 means not Auto Report not set)

- Re-trigger Interval Setting (for PIR sensor only)
The parameter adjusts the sleep period after the detector has been triggered. No response will be made during this interval if a movement is presented. Longer re-trigger interval will result in longer battery life.

Parameter Number	Size	Range	Default
2	2	10~3600(sec)	180

- Trigger Off Interval Setting
This controls how long the connected lighting will stay on after the motion is detected This is useful for Group 2 associations where the detector is connected directly to another device such as smartplugs.

Parameter Number	Size	Range	Default
3	2	10~3600(sec)	15

Troubleshooting

The table below lists the several steps involved when adding or removing the detector from the Z-Wave network.

Action/Status	Description	LED indication
No node ID	The Z-Wave Controller does not allocate a node ID to the unit.	2-second on, 2-second off For 2 minutes
Auto Inclusion	The power is applied for the first time and no node ID has been stored in the module, or after executing reset.	
Manual Inclusion	1. Put the Z-Wave Controller into inclusion mode. 2. Press the learn key 3 times within 1.5 seconds to put the unit into inclusion mode.	
Exclusion	1. Put the Z-Wave Controller into exclusion mode. 2. Press the learn key 3 times within 1.5 seconds to put the unit into exclusion mode.	
Factory Reset (This procedure should only be used when the controller is inoperable.)	1. Press the learn key 3 times within 1.5 seconds to put the unit into exclusion mode. 2. Within 1 second of step 1, press the learn key again and hold for 5 seconds. 3. Node ID is excluded. The device reverts to factory default state.	2-second on, 2-second off For 2 minutes

* Failed or successful results in including/excluding the ID can be viewed on the Z-Wave Controller.

Note: If you are connecting this unit to a Z-wave Controller that utilizes the S2 security protocol, you may be asked by your controller to enter a 5 digit Device Specific Key (DSK) that is unique to each unit. This can be found in one of two places:

- on the QR code label on the back of the unit
- on the insert card inside the packaging

Table below lists typical problems encountered:

Symptom	Possible Cause	Recommendation
LED on the detector does not turn on when battery is inserted	Battery is not fitted properly or run out of battery power.	Check if batteries are fitted or replace a new battery.

Cannot carry out inclusion and association	Device has been paired to other Z-Wave controller.	1. Perform Exclusion from other controller first then carry out inclusion with new controller. 2. Perform Factory Reset on device and then carry out Inclusion with new controller.
Detector trigger by itself	Check if the detector is mounted above a radiator or heater	Remove the source of interference or reposition its mounting location
Z-Wave controller cannot communicate with the unit	Device is out of range.	1. Relocate the controller closer to the unit. 2. Install a Z-Wave repeater such as smart plugs or other AC devices that can operate as a Repeater.

Specifications

Battery	CR123A battery x 1
Range	Up to 100 meters line of sight
Frequency Range	EU: 868.42MHz, US: 908.42 MHz
PIR Warm Up Time	About 1 minute
PIR Detection Coverage	Up to 12m x 90° (at 2m mounting height & 25 °C)
PIR Pet Immunity	Height ≤60cm; Length ≤90cm
Temperature sensor range	-10 ~ 40°C ± 2 °C
Humidity sensor range	0 ~ 80%RH ± 15%RH

Specifications are subject to change without notice



Federal Communication Commission Interference Statement

This device complies with Part 15 of the FCC Rules. Operation is subject to the following two conditions: (1) This device may not cause harmful interference, and (2) this device must accept any interference received, including interference that may cause undesired operation.

This equipment has been tested and found to comply with the limits for a Class B digital device, pursuant to Part 15 of the FCC Rules. These limits are designed to provide reasonable protection against harmful interference in a residential installation. This equipment generates uses and can radiate radio frequency energy and, if not installed and used in accordance with the instructions, may cause harmful interference to radio communications. However, there is no guarantee that interference will not occur in a particular installation. If this equipment does cause harmful interference to radio or television reception, which can be determined by turning the equipment off and on, the user is encouraged to try to correct the interference by one of the following measures:

- Reorient or relocate the receiving antenna.
- Increase the separation between the equipment and receiver.
- Connect the equipment into an outlet on a circuit different from that to which the receiver is connected.
- Consult the dealer or an experienced radio/TV technician for help.

FCC Caution: Any changes or modifications not expressly approved by the party responsible for compliance could void the user's authority to operate this equipment.

This transmitter must not be co-located or operating in conjunction with any other antenna or transmitter.

Radiation Exposure Statement:

This equipment complies with FCC radiation exposure limits set forth for an uncontrolled environment. This equipment should be installed and operated with minimum distance 20cm between the radiator & your body.

Industry Canada statement:

This device complies with ISED's license-exempt RSSs. Operation is subject to the following two conditions: (1) This device may not cause harmful interference, and (2) this device must accept any interference received, including interference that may cause undesired operation.

Le présent appareil est conforme aux CNR d' ISED applicables aux appareils radio exempts de licence. L'exploitation est autorisée aux deux conditions suivantes : (1) le dispositif ne doit pas produire de brouillage préjudiciable, et (2) ce dispositif doit accepter tout brouillage reçu, y compris un brouillage susceptible de provoquer un fonctionnement indésirable.

Radiation Exposure Statement:

This equipment complies with ISED radiation exposure limits set forth for an uncontrolled environment. This equipment should be installed and operated with minimum distance 20cm between the radiator & your body.

Déclaration d'exposition aux radiations:

Cet équipement est conforme aux limites d'exposition aux rayonnements ISED établies pour un environnement non contrôlé. Cet équipement doit être installé et utilisé avec un minimum de 20 cm de distance entre la source de rayonnement et votre corps.

WARNING:

Do not dispose of electrical appliances as unsorted municipal waste, use separate collection facilities. Contact your local government for information regarding the collection systems available. If electrical appliances are disposed of in landfills or dumps, hazardous substances can leak into the groundwater and get into the food chain, damaging your health and well-being. When replacing old appliances with new ones, the retailer is legally obligated to take back your old appliance for disposal at least for free of charge.



EVERSPRING

www.everspring.com
50 Sect. 1 Zhonghua Rd Tucheng
NewTaipeiCity 236 Taiwan..