

# SP816

# OUTDOOR MOTION DETECTOR

The SP816 Outdoor Motion Detector is a Z-Wave Plus™ enabled device and is fully compatible with any Z-Wave™ enabled network. The device can be set up in a Z-wave network to communicate directly with other end devices such as lighting controllers, or to report directly to a Z-wave controller (usually a gateway).

This motion detector is primarily designed for outdoor lighting control application. It features a PIR motion detector to detect movement in a protected area and a lux sensor for determining brightness of its surroundings. It comes with a built in timer to set the duration for light turn on. The lux level and the timer can be set through knobs on the device itself.

If the PIR detects motion when lux level falls below a preset setting, the device will transmit a signal to turn on the outdoor lighting (or indirectly through gateway) and then later turns it off when its timer has elapsed.

This device can also be used as a basic motion sensor for indoor security application.

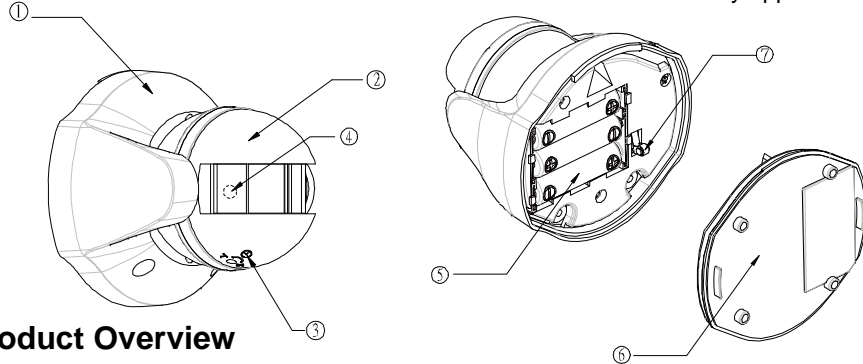

## Product Overview

① Front Cover	⑤ Battery
② Motion Sensor	⑥ Rear Cover
③ Time-off / Lux Knob	⑦ Tamper Switch
④ LED indicator (hidden behind lens)	

## Adding to Z-Wave™ Network

### Auto Inclusion

The detector supports Auto Inclusion feature where it will automatically enter Inclusion mode when first powered up after a factory reset.

1. Use a screwdriver to detach the rear cover.

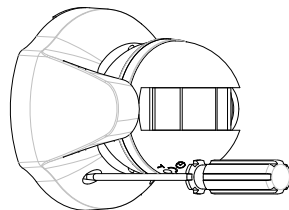

2. Put a Z-Wave Controller into inclusion mode.

3. Insert 3 AA-size 1.5V batteries to the battery compartment with the correct polarity. The LED on the device should turn ON..

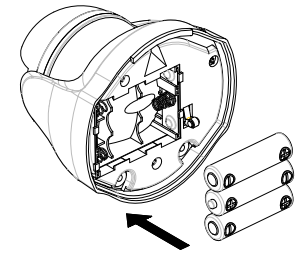

4. The Inclusion process should be completed when the LED stops blinking.
5. Do not refit the rear cover yet.

Note: If Auto Inclusion fails, refer to the Troubleshooting section regarding Manual Inclusion.

## Testing

### Warm-Up

It will take approximately 1 minute for the detector to warm up after a battery is inserted. During this period the LED behind the lens will turn on. When the LED turns off, it implies warm-up procedure is complete and the detector is ready for detection.

Note:

- This will not affect the Inclusion/Exclusion process.
- After removing batteries, wait for 5 seconds to refit batteries.

### Quick Test

1. With the tamper switch not being pressed, the unit will enter Test mode to allow the user to test the device before it is mounted on the wall.
2. During Test mode, if movement is detected, the LED on the detector will illuminate implying the unit is working properly.
3. To exit the Test mode, simply press the Tamper switch for more than 10 seconds to enter Normal mode.

## Mounting the Detector

### Choosing the location

The recommended location for the detector is outside the house under the eaves or other shaded areas where it is not directly exposed to sunlight. Though the detector is waterproof (IP44 rated), avoid direct contact with rain.

- Do not position the detector facing a window or direct sunlight.

- Do not position the detector directly above or facing any source of heat, eg: fires, radiators, boiler etc.

- Where possible, mount the detector so that the path of an intruder would cut across the fan pattern rather than directly towards the detector.

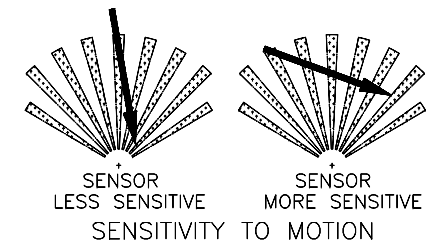

mount the detector 2m from the floor. At this height, the detector will detect movement within its 100 degrees fan-shaped detection pattern up to 6-12m depending on adjustment. .

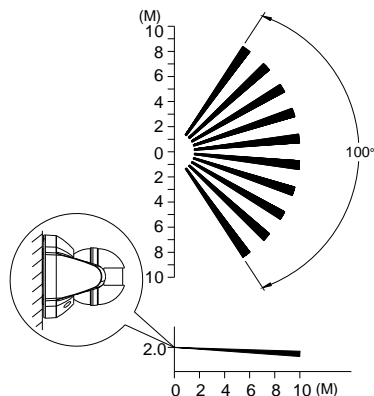

## Installation

1. Use the rear cover to mark the two mounting holes.
2. Drill the holes, insert the plastic wall plugs and screw the rear cover to the wall using the screws supplied.
3. Assemble the detector back to its rear cover using screws as originally supplied.

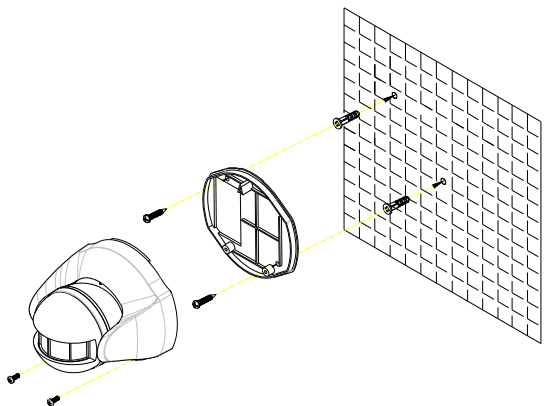

4. The detector will enter Normal mode after 10 seconds.

## Walk Test

The user can perform a walk test to ensure the detector's detection range falls within the desired area of coverage. This test also checks if the detector is still within the communication range of the controller. For this test, the detector needs to be configured to turn on a connected lighting or other observable action set using the controller.

1. On the detector, turn both knobs Time-Off and Lux to the "T" mark.
2. Walk into the detector's range and check if the connected lighting turns on and off.
3. If necessary, tilt the head of the detector to achieve desired result.

## Operation

When the detector is mounted on the wall, i.e. tamper switch is pressed, for more than 10 seconds, it will enter Normal mode.

- Upon motion being sensed, the detector will turn ON the connected lighting. After the elapse of preset time-off, the detector will turn OFF the connected lighting (see Time adjustment knob below).

- In Normal mode, the red indicator LED on the detector will not illuminate when the detector is triggered in order to conserve battery life, unless the battery is low.

- If the Tamper switch is released, the detector will send a Notification command

### (1) Time adjustment

Time-off knob controls how long the connected lighting will stay on after the motion is detected. It can be set from 5 seconds to 12 minutes.

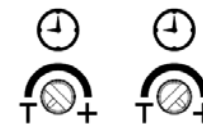

About 5 seconds

About 12 minutes

"T" means 5 seconds, while "+" is 12 minutes. After the expiry of preset time-off, the detector will send a turn OFF signal.

### (2) Lux adjustment

The LUX adjustment sets the brightness level threshold that will activate the motion sensor in the detector.

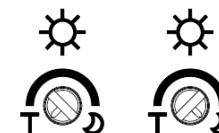

For instance, turning the LUX knob clockwise to the MOON position will activate detector's motion sensor only night and inactivated during the day. The adjustable Lux range is about 30 - 200 Lux.

To set the lux level:

1. Turn the Time-off knob to "T" for maximum response.
2. Turn the LUX control knob to the edge clockwise at the "moon" (dusk) position.
3. Wait until the ambient light level reaches the level of darkness at which you wish the detector to activate.
4. Slowly rotate the Lux knob while anti-clockwise while keep creating motion during the process until the detector sends out a signal to turn on the connected lighting. At this position the light should become operative at approximately the same level of darkness each evening
5. Set the Time-off knob back to the desired preset time.

## Maintenance

Low Battery: When the battery becomes low, the LED will flash for 1 second when motion is detected in Normal mode to indicate low battery condition to the user.

When the battery becomes low in Test mode, the LED will flash once every 30 seconds.

## Programming

### Z-Wave Group

The detector supports either one of two Z-wave Association Groups:

**Group 1:** Association with 1 Controller node.

**Group 2:** Association with 4 nodes (i.e. end devices such as smart plugs and other lighting controllers). This allows the detector to transfer commands directly to end devices without the participation of the controller. This has the effect that when the detector triggers, all devices associated with detector will be operated.

Group 1 commands:

- When the unit is powered up and was already a part of a Z-Wave network, the unit will send a Notification Report to the node in Group 1.
- When the detector senses a movement, the unit will send a Notification Report to the nodes of Group 1. Once the movement is stopped, a Notification Report will be sent again to Group 1.
- Upon detector status being changed, the unit will check its battery status simultaneously. When the battery level of the unit drops to an unacceptable level, the unit will emit Battery report to the nodes of Group 1.
- When performing Factory Reset the unit will send Device Reset Locally Notification to the node of Group1.

Group 2 commands:

- When the detector is triggered, the unit will send BASIC\_SET command which contains a value to the nodes of Group 2.

### Z-Wave Plus Info

Role Type	Node Type	Installer Icon	User Icon
Slave Sleeping report	Z-Wave Plus node	Sensor Notification Device Type (Home Security)	Sensor Notification Device Type (Home Security)

### Version

Protocol Library	3 (Slave_Enhance_232_Library)
Protocol Version	4.3D ( 6.71.01)

### Manufacturer

Manufacturer ID	Product Type	Product ID
0x0060	0x0001	0x0005

### AGI (Association Group Information) Table

Group	Profile	Command Class & Command (List) N bytes	Group Name(UTF-8)
1	General	Battery Report Notification Report Device Reset Locally Notification	Lifeline
2	Control	Basic Set	PIR Control

### Notification

Event	Type	Event	Event Parameters Length	Event Parameters
The power is applied for the first time	0x08	0x01	0x00	
PIR Trigger ON	0x07	0x08	0x00	
PIR Trigger OFF	0x07	0x00	0x01	0x08
Tamper switch being press more than 10 seconds	0x07	0x00	0x01	0x03
Tamper switch being press more than 10 seconds and released	0x07	0x03	0x01	

### Battery

Battery Report (value)	Description
20~100	Battery Level (%)
0xFF	Low Battery

### Command Classes

The module supports Command Classes including...

- COMMAND\_CLASS\_ZWAVEPLUS\_INFO\_V2
- COMMAND\_CLASS\_ASSOCIATION\_V2
- COMMAND\_CLASS\_ASSOCIATION\_GRP\_INFO
- COMMAND\_CLASS\_TRANSPORT\_SERVICE\_V2
- COMMAND\_CLASS\_VERSION\_V2
- COMMAND\_CLASS\_MANUFACTURER\_SPECIFIC\_V2
- COMMAND\_CLASS\_DEVICE\_RESET\_LOCALLY
- COMMAND\_CLASS\_POWERLEVEL
- COMMAND\_CLASS\_SECURITY
- COMMAND\_CLASS\_SECURITY\_2
- COMMAND\_CLASS\_SUPERVISION
- COMMAND\_CLASS\_FIRMWARE\_UPDATE\_MD\_V4
- COMMAND\_CLASS\_BATTERY
- COMMAND\_CLASS\_WAKE\_UP\_V2
- COMMAND\_CLASS\_NOTIFICATION\_V4

### Wakeup Command Class

After it has been included into a Z-wave network, the detector will go to sleep but will send a Wakeup Notification Command periodically at preset period to the controller. The Motion detector will stay awake for 10 seconds at least and then go back to sleep to conserve battery life.

The time interval between Wakeup Notification Commands can be set in the Wakeup Command Class based on the range values below:

Minimum Wake Up Interval	600s (10 minutes)
Maximum Wake Up Interval	86400s (1 day)
Default Wake Up Interval	14400s (4 hours)
Wake Up Interval Step Seconds	600s (10 minutes)

## Troubleshooting

The table below lists the several steps involved when adding or removing the detector from the Z-wave network.

Action/Status	Description	LED indication
No node ID	The Z-Wave Controller does not allocate a node ID to the unit.	2-second on, 2-second off For 2 minutes
Auto Inclusion	The power is applied for the first time and no node ID has been stored in the module, or after executing reset.	
Manual Inclusion	1. Put the Z-Wave Controller into inclusion mode.	
	2. Press the tamper switch 3 times within 1.5 seconds to put the unit into inclusion mode.	
Exclusion	1. Put the Z-Wave Controller into exclusion mode.	
	2. Press the tamper switch 3 times within 1.5 seconds to put the unit into exclusion mode.	
	2. Within 1 second of step 1, press the tamper switch again and hold until LED is off (about 5 seconds).	
	3. Node ID is excluded. The device reverts to factory default state and will be in auto-inclusion mode for 4 minutes.	
* Failed or successful results in including/excluding the ID can be viewed on the Z-Wave Controller.		

Table below lists typical problems encountered:

Symptom	Possible Cause	Recommendation
Cannot carry out inclusion and association	1. Run out of battery power 2. Check if reverse battery polarity 3. Check if the detector is out of order	1. Replace a new battery 2. Refit the battery with correct polarity 3. Ensure the detector is working properly
Cannot control the connected modules	1. Run out of battery power 2. Check if the detector is out of order	1. Replace a new battery 2. Ensure the detector is working properly
The detector not working	1. Run out of battery power 2. Check if the mounting location is proper 3. Check if the detector is mounted above a radiator or heater 4. Check if the detector is out of order	1. Replace a new battery 2. Reposition its mounting location 3. Remove the source of interference or reposition its mounting location 4. Ensure the detector is working properly

## Specifications

Battery	1.5V AA size x 3
Battery Life	1 year*
Range	Up to 100 meters line of sight
Warm Up Time	About 1 minute
PIR Detection Coverage	Up to 10m x 100° (at 2m mounting height & below 20°C)
Frequency Range	908.42 MHz (US) / 868.42 MHz (EU)

*Specifications are subject to change without notice*

*\*measured at 10 triggers per day*



### Federal Communication Commission Interference Statement

This equipment has been tested and found to comply with the limits for a Class B digital device, pursuant to Part 15 of the FCC Rules. These limits are designed to provide reasonable protection against harmful interference in a residential installation. This equipment generates, uses and can radiate radio frequency energy and, if not installed and used in accordance with the instructions, may cause harmful interference to radio or television reception, which can be determined by turning the equipment off and on, the user is encouraged to try to correct the interference by one of the following measures:

- Reorient or relocate the receiving antenna.
- Increase the separation between the equipment and receiver.
- Connect the equipment into an outlet on a circuit different from that to which the receiver is connected.
- Consult the dealer or an experienced radio/TV technician for help.

This device complies with Part 15 of the FCC Rules. Operation is subject to the following two conditions: (1) This device may not cause harmful interference, and (2) this device must accept any interference received, including interference that may cause undesired operation.

FCC Caution: Any changes or modifications not expressly approved by the party responsible for compliance could void the user's authority to operate this equipment.

This transmitter must not be co-located or operating in conjunction with any other antenna or transmitter.

#### WARNING:

Do not dispose of electrical appliances as unsorted municipal waste, use separate collection facilities.

Contact your local government for information regarding the collection systems available.

If electrical appliances are disposed of in landfills or dumps, hazardous substances can leak into the groundwater and get into the food chain, damaging your health and well-being.

When replacing old appliances with new ones, the retailer is legally obligated to take back your old appliance for disposal at least for free of charge.



EVERSPRING  
www.everspring.com

50 Sect. 1 Zhonghua Rd Tucheng  
NewTaipeiCity 236 Taiwan

A501112630R